

5-2013

# Mitigating Shrinkage Cracking of Concrete in Bridge Decks Through Internal Curing

Daniel Robert Goad

*University of Arkansas, Fayetteville*

Follow this and additional works at: <http://scholarworks.uark.edu/etd>

 Part of the [Transportation Engineering Commons](#)

---

## Recommended Citation

Goad, Daniel Robert, "Mitigating Shrinkage Cracking of Concrete in Bridge Decks Through Internal Curing" (2013). *Theses and Dissertations*. 668.

<http://scholarworks.uark.edu/etd/668>

This Thesis is brought to you for free and open access by ScholarWorks@UARK. It has been accepted for inclusion in Theses and Dissertations by an authorized administrator of ScholarWorks@UARK. For more information, please contact [scholar@uark.edu](mailto:scholar@uark.edu), [ccmiddle@uark.edu](mailto:ccmiddle@uark.edu).



MITIGATING SHRINKAGE CRACKING OF CONCRETE IN BRIDGE DECKS THROUGH  
INTERNAL CURING

MITIGATING SHRINKAGE CRACKING OF CONCRETE IN BRIDGE DECKS THROUGH  
INTERNAL CURING

A thesis submitted in partial fulfillment  
of the requirements for the degree of  
Master of Science in Civil Engineering

By

Daniel Robert Goad  
University of Arkansas  
Bachelor of Science in Civil Engineering, 2010

May 2013  
University of Arkansas

## Abstract

As the need for durable, long lasting infrastructure increases, new methods and techniques are being explored to prolong the service life of roads and bridges. One method to reduce shrinkage and early age cracking in concrete is internal curing. Internal curing supplies water to concrete, using pre-wetted lightweight aggregate (LWA), as needed throughout the process of hydration to reduce self desiccation, which leads to cracking. This research project analyzed two types of coarse LWA, expanded clay and expanded shale. The mixtures were developed specifically for use in bridge decks and adhered to specifications of the Arkansas State Highway and Transportation Department (AHTD). The concrete mixtures contained LWA at rates of 0, 100, 200, and 300 lb/yd<sup>3</sup>. The research was divided into two phases. The first phase measured autogenous and drying shrinkage in both plastic and elastic states using embedded vibrating wire strain gages (VWSG) cast in concrete prisms. The expanded clay LWA mixtures, with the 300 lb. replacement rate yielding the best results, were most effective in reducing shrinkage. Compressive strength decreased as the amount of LWA included in the mixture increased. However, all mixtures surpassed the 28 day compressive strength specified by AHTD. The second phase of the research project measured plastic shrinkage cracking in thin concrete test slabs. Methods and materials were investigated to produce consistent plastic shrinkage surface cracks of the concrete slabs. The extent of plastic shrinkage that occurred was quantified by measuring the total crack area of the test slabs. Implementation of 300 lb. of expanded clay LWA did not reduce the crack lengths, but did reduce the average crack widths experienced by the test slabs due to plastic shrinkage.

This thesis is approved for recommendation  
to the Graduate Council.

Thesis Director:

---

**Dr. W. Micah Hale**

Thesis Committee:

---

**Dr. Kirk Grimmelsman**

---

**Dr. Ernest Heymsfield**

## Thesis Duplication Release

I hereby authorize the University of Arkansas Libraries to duplicate this thesis when needed for research and/or scholarship.

**Agreed** \_\_\_\_\_  
Daniel Robert Goad

**Refused** \_\_\_\_\_  
Daniel Robert Goad

## **Acknowledgments**

I first want to give all credit to Jesus Christ for the many blessings and opportunities I have been given throughout my life. I cannot thank Dr. Micah Hale enough for giving me the opportunity to further my education. His professional example and guidance have made a lasting impact on both my personal and professional life.

I would like to thank my wife, Ashton, for her unwavering support and love as I worked to complete my master's degree. I would not have been able to complete this work without her by my side. I would also like to thank my parents and family for their support and encouragement throughout my time in graduate school.

The experimental work could not have been completed without the help of other graduate students. I would first like to thank Casey Jones, who worked with me in all phases of research. We spent many hours working together in the laboratory, and this research would not be completed without his influence. I would also like to thank Richard Deschenes, Jared Bymaster, Jonathan Kerby, and Dr. Royce Floyd for their help during the hot summer months. Previous research and testing on light weight aggregate done by Dr. Royce Floyd was very helpful in our testing and research of internal curing.

I would like to thank the University of Arkansas Civil Engineering Department for providing the tremendous opportunity to obtain my graduate degree. Lastly, I would like to thank the Arkansas State Highway and Transportation Department (AHTD) for funding this research. It is my hope that this work will aid the AHTD in the future decisions concerning reducing cracking in bridge decks.



## Table of Contents

<b>Chapter 1 Introduction.....</b>	<b>1</b>
1.1 Overview .....	1
1.2 Research Significance .....	1
1.3 Research Scope .....	2
<b>Chapter 2 Literature Review .....</b>	<b>4</b>
2.1 History of Internal Curing .....	4
2.2 Theory of Internal Curing .....	5
2.3 The Use of Internal Curing in Conventional Concrete Mixtures .....	6
2.4 Why Use Internal Curing?.....	7
2.5 Effects of Internal Curing on Properties of Concrete.....	8
2.5.1 Compressive strength.....	8
2.5.2 Modulus of Elasticity.....	9
2.6 Types of Concrete Shrinkage .....	9
2.6.1 Plastic Shrinkage.....	10
2.6.2 Autogenous and Chemical Shrinkage.....	15
2.6.3 Drying Shrinkage .....	17
2.7 Lightweight Aggregate.....	21
2.7.1 Manufacturing LWA.....	22
2.7.2 Mixture Proportioning of LWA .....	23
2.8 Summary .....	25
<b>Chapter 3 Experimental Procedures.....</b>	<b>26</b>
3.1 Purpose.....	26
3.2 Materials.....	26
3.2.1 Mixtures .....	26
3.2.2 Cementitious Material and Admixtures .....	27
3.2.3 Normal-weight Coarse Aggregate .....	27
3.2.4 Fine Aggregate.....	28
3.2.5 Coarse Lightweight Aggregate (LWA) .....	28
3.3 Phase I - Drying Shrinkage Testing .....	29
3.3.1 Mixing Procedure and Aggregate Preparation.....	30
3.3.2 ASTM C157- Linear Length Change .....	31
3.3.3 Compressive Strength Cylinders.....	34
3.3.4 Strain Gage Testing- Linear Length Change .....	35
3.4 Phase II - Plastic Shrinkage Testing.....	40
3.4.1 Mixing Procedure and Aggregate Preparation.....	41
3.4.2 Mixtures .....	41
3.4.3 Formwork.....	42
3.4.4 Casting Procedure .....	42
3.4.5 Environmental Conditions .....	43
3.4.6 Crack Measurements.....	44
<b>Chapter 4 Results and Discussion.....</b>	<b>46</b>
4.1 Phase I: Preliminary Shrinkage Data using ASTM C157 .....	46
4.1.1 Mixture Proportions .....	46
4.1.2 Fresh Properties .....	46

4.1.3	Compressive Strength .....	47
4.1.4	Moisture Content .....	48
4.1.5	Shrinkage Results.....	49
4.2	Phase I: Shrinkage Data using Strain Gages .....	51
4.2.1	Mixture Proportions .....	52
4.2.2	Fresh Properties .....	52
4.2.3	Compressive Strength .....	53
4.2.4	Moisture Content .....	54
4.2.5	Shrinkage Results.....	54
4.2.6	Temperature Results .....	63
4.2.7	Data Comparison between ASTM C157 and Strain Gage Results.....	65
4.3	Phase II: Plastic Shrinkage Testing.....	66
4.3.1	Mixtures .....	66
4.3.2	Developing Test Slabs .....	67
4.3.3	Slump .....	73
4.3.4	Environmental Conditions .....	74
4.3.5	Plastic Shrinkage Cracking Results .....	74
<b>Chapter 5</b>	<b>Conclusions.....</b>	<b>76</b>
5.1	Phase I- Drying Shrinkage Conclusions.....	76
5.2	Phase II- Plastic Shrinkage Conclusions.....	76
5.3	Recommendations for Future Research .....	77
<b>References.....</b>		<b>78</b>

## Table of Figures

Figure 2.1	Comparison Between External Curing and Internal Curing.....	6
Figure 2.2	ASTM C 1579 Formwork and Stress Riser Geometry.....	13
Figure 2.3	Formwork for Thin Slabs .....	15
Figure 2.4	Chemical and Autogenous Shrinkage Volumes During Hydration of a Paste with a w/cm of 0.30 .....	16
Figure 2.5	Concrete Cracking Due to Drying Shrinkage.....	18
Figure 2.6	Effect of Relative Aggregate Content and Modulus Ratio on Drying Shrinkage of Concrete .....	20
Figure 2.7	Linear Comparator and Prism used in ASTM C157 .....	21
Figure 2.8	Manufacturing Process of Expanded Clay, Shale, and Slate.....	23
Figure 3.1	Expanded Clay LWA (left) and Expanded Shale LWA (right) .....	29
Figure 3.2	Rotating Drum Mixer .....	31
Figure 3.3	Steel Molds.....	32
Figure 3.4	Length Comparator with Digital Indicator .....	33
Figure 3.5	Concrete Testing Machine.....	35
Figure 3.6	Vibrating Wire Strain Gage Placement in Steel Molds.....	36
Figure 3.7	Wrapped Steel Molds During First 24 Hours.....	37
Figure 3.8	Concrete Prisms.....	38
Figure 3.9	Model 4200 Vibrating Wire Strain Gage .....	39
Figure 3.10	One Cubic Yard Rotating Drum Mixer .....	41
Figure 3.11	Formwork Details.....	42
Figure 3.12	Environmental Conditions.....	44
Figure 3.13	Test Slab During Crack Measurements.....	45
Figure 4.1	ASTM C157 Strain results (28 days) .....	50
Figure 4.2	ASTM C157 Strain results (112 days) .....	51
Figure 4.3	Expanded Clay Strain (24 hours) .....	57
Figure 4.4	Expanded Shale Strain (24 hours) .....	58
Figure 4.5	Expanded Clay Strain (7 days) .....	59
Figure 4.6	Expanded Shale Strain (7 days).....	60
Figure 4.7	Expanded Clay Strain (28 days) .....	61
Figure 4.8	Expanded Shale Strain (28 days).....	61
Figure 4.9	Expanded Clay Strain (112 days) .....	63
Figure 4.10	Expanded Shale Strain (112 days).....	63
Figure 4.11	Temperature Decrease of Control Mixture.....	64
Figure 4.12	4' x 4' Test Slab .....	68
Figure 4.13	Slab After Formation of Plastic Shrinkage Cracks.....	71
Figure 4.14	Slab Cracks Mapped 24 Hours After Casting .....	71

## Table of Tables

Table 2.1	Calculated coefficients for Chemical Shrinkage Due to Cement Hydration .....	24
Table 3.1	Mixture Proportions .....	27
Table 3.2	Limestone Gradation.....	28
Table 3.3	Fine Aggregate Gradation.....	28
Table 3.4	Coarse Aggregate Properties .....	29
Table 4.1	Fresh Properties .....	47
Table 4.2	Compressive Strength.....	48
Table 4.3	Assumed vs. Actual LWA Moisture Contents.....	48
Table 4.4	Standard Deviation of Preliminary Strain Readings.....	49
Table 4.5	Fresh Properties .....	53
Table 4.6	Compressive Strength.....	53
Table 4.7	Assumed vs. Actual LWA Moisture Contents.....	54
Table 4.8	Standard Deviations of VW Strain Gage Results .....	55
Table 4.9	Comparative Strain Readings .....	65
Table 4.10	Mixture Proportions for Test Slabs.....	72
Table 4.11	Slab Data.....	75

## **Chapter 1 Introduction**

### **1.1 Overview**

Curing of concrete has long since been utilized in the construction industry in regards to bridge decks. Curing increases concrete strength and durability while supplying additional water to reduce shrinkage and early age cracking. The vast majority of today's curing procedures are done externally. Common practices of external curing include ponding, fogging, misting, and wet burlap applications (Bentz & Weiss, 2011). While external curing is important to counteract premature moisture loss, it has shown only to penetrate millimeters into the concrete surface, especially in the case of high performance concrete (Bentz, 2002). Internal curing is a relatively new method that supplies additional moisture needed during hydration, not just to the surface of the concrete, but throughout the concrete matrix. Internal curing is defined by the American Concrete Institute (ACI) as "supplying water throughout a freshly placed cementitious mixture using reservoirs, via pre-wetted lightweight aggregates, that readily release water as needed for hydration or to replace moisture lost through evaporation or self-desiccation" (ACI, 2010).

### **1.2 Research Significance**

A goal of internal curing is to reduce the strain in concrete mixtures which directly influences the potential of concrete to crack. Designers have to take preventative measures in an effort to reduce or eliminate shrinkage cracking in bridge decks and concrete pavements throughout the U.S. However, in many cases these preventative measures are not sufficient in eliminating cracking. Early age cracking of concrete can significantly decrease the durability and, consequently, the design life of the structure. Research findings have shown that the effects of internal curing on concrete shrinkage can help in the effort to extend the life of concrete structures as well as reducing costly repairs or replacements whose structural integrity or

serviceability is weakened through the influence of shrinkage cracking. In past research, internal curing has been studied mostly for its use in high-performance concrete (HPC) due to its increased need for moisture throughout the hydration process. However, limited research has been conducted for the effects of internal curing in conventional concrete, or concrete with a higher water to cement ratio (w/cm), due to the assumption that the concrete matrix contains sufficient water to allow full hydration. Bridge decks cast with conventional concrete are still experiencing early age cracking, so the goals of this research are to examine the effects that internal curing have on conventional concretes to determine if the implementation of internal curing can mitigate early age cracking in bridge decks. The purposes of this research are not to replace common external curing methods, but to find ways to supplement the curing of concrete that may result in increased service life of structures in the future.

### **1.3 Research Scope**

For this research, internal curing was provided by two types of coarse lightweight aggregate (LWA); expanded clay and expanded shale. These LWA's were submerged in water prior to batching so that the internal pores of the LWA would contain water that could be released into the concrete matrix throughout the hydration process. The research discussed herein was performed in two phases. The first phase of the research examined the effects of internal curing on autogenous and drying shrinkage using embedded vibrating wire strain gages (VWSG) cast in concrete prisms to monitor strain. The strains in the concrete prisms were measured from the time of casting out to 112 days. The LWA's were added in varying replacement rates and compared with a Control to examine the effects on strain as well as compressive strength. The second phase examined the effects of internal curing on plastic shrinkage cracking of test slabs. This phase investigated experimental methods to consistently produce plastic shrinkage cracks in

concrete test slabs, and examined if the implementation of LWA affected the degree of plastic shrinkage cracking that occurred.

## **Chapter 2 Literature Review**

### **2.1 History of Internal Curing**

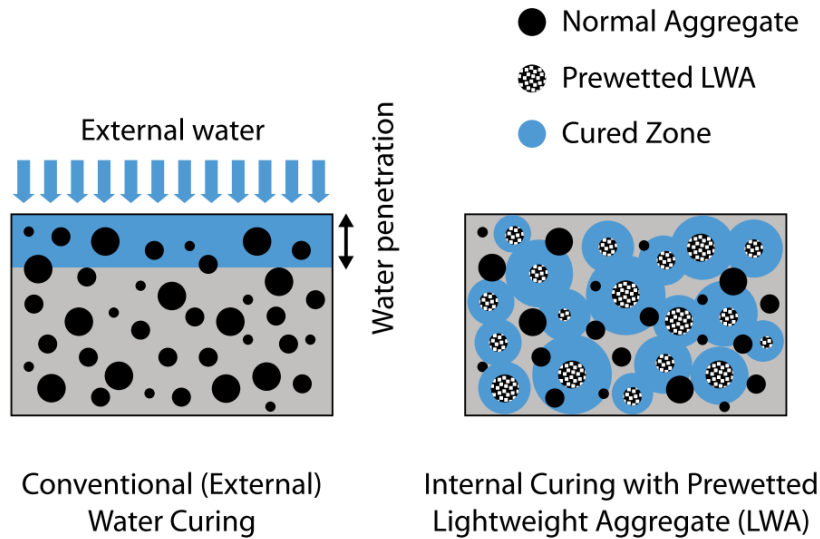
Internal curing of concrete most likely began before the benefits were realized. The Romans used porous aggregates such as pumice and scoria in some of their structures, most notably the dome of the Pantheon (Bremner & Ries, 2009). Its use, however, was not for the increased curing capabilities of the LWA. The LWA was used to decrease dead loads of the concrete itself. The realization of the significance of internal curing through LWA came much later in history by Paul Klieger in 1957 stating, “Lightweight aggregates absorb considerable water during mixing which apparently can transfer to the paste during hydration” (Bentz & Weiss, 2011). The high amount of variance in the properties of naturally occurring LWA made implementing these aggregates in construction a struggle. It wasn’t until Stephen Hayde patented a method of manufacturing LWA, that a broader use of LWA’s could be accomplished (though it happened long after Hayde’s patent in 1914) (Bremner & Ries, 2009). Hayde developed a method of rapidly cooking shale, slate, and clay in a rotary kiln at high temperatures where the gases could not escape the aggregate, causing it to expand and creating its porous structure.

During the 1990’s internal curing research was being performed in several countries including work by Weber and Reinhardt (Bentz & Weiss, 2011). They investigated the use of pre-wetted LWA for its use in internal curing (Weber & Reinhardt, 1995). Other water-carrying reservoirs investigated included wood fibers and superabsorbent polymers (SAP) (Bentz & Weiss, 2011). Internal curing has been studied in much more depth for its use in high performance concretes (HPC) because of increased hydration in these low w/cm concretes. Research of internal curing in concrete remains a relatively new area of study to this day.



## 2.2 Theory of Internal Curing

ACI defines curing as “action taken to maintain moisture and temperature conditions in a freshly placed cementitious mixture to allow hydraulic cement hydration and (if applicable) pozzolanic reactions to occur so that the potential properties of the mixture may develop” (ACI, 2010). The goal of internal curing is to maintain conditions so that increased hydration may occur by providing an internal source of water. In most cases, the internal source of water is provided by pre-wetted LWA. Through the process of hydration, water and cement react forming hydration products. These hydration products occupy less volume than water in its bulk form (Bentz & Weiss, 2011). This reduction in volume can leave void spaces in the cement matrix inducing tensile stress as the presence of water diminishes. Internal curing provides additional water that is stored within the aggregate pore structure. As hydration occurs and water is consumed in the cement paste, water from the LWA is drawn back into the paste to further the degree of hydration. The nature of the manufactured LWA is that its pores are larger than the pores in the cement paste. Studies using X-Ray absorption of cement materials indicated that water will move from coarse to finer pores (Bentz, Hansen, Madsen, Vallee, & Griesel, 2001). As water is consumed and the relative humidity drops, water is drawn out of the larger pores in the LWA and into the smaller pores of the cement paste (Figure 2.1).



**Figure 2.1 Comparison Between External Curing and Internal Curing (Weiss, Bentz, Schindler, & Lura, 2012)**

### 2.3 The Use of Internal Curing in Conventional Concrete Mixtures

Most internal curing research has focused on HPC mixtures that possess a low w/cm and high cement content. These mixtures contain insufficient water content to fully hydrate the cement. In addition, the dense nature of HPC results in low permeability, which decreases the effectiveness of external curing (Espinoza-Hijazin & Lopez, 2011). However, for the research discussed herein, concrete mixtures with a w/cm equal to 0.44 were analyzed that do not fall into the category of HPC. In theory, mixtures with w/cm greater than 0.36 have enough water without internal curing to assume 100 percent hydration, assuming extended and saturated curing conditions are present (Bentz, Lura, & Roberts, 2005). However, in many job site applications, saturated and ideal curing conditions can be impractical. Environmental conditions paired with shorter-than-ideal curing periods can lead to moisture loss resulting in decreased hydration. Espinoza-Hijazin and Lopez found a 15 percent increase in the degree of hydration, a 19 percent increase in 90 day compressive strength, and a 30 percent decrease in chloride ion permeability

in conventional concrete using internal curing when compared to no internal curing used. They stated, "...the mixtures with internal curing showed less water effectively lost than the mixtures without it, That is, internal curing was able to maintain better curing conditions for the cement paste even under drying conditions" (Espinoza-Hijazin & Lopez, 2011).

Research done by Kansas University evaluated the effect of internal curing through LWA in concretes with a w/cm equal to 0.44 (Reynolds, Browning, & Darwin, 2009). They evaluated three different replacement rates of intermediate LWA: low, medium, and high replacement rates (8.4, 11.3, and 13.8 percent aggregate by volume). In almost every mix, the addition of LWA reduced the free shrinkage of the concrete at both 30 and 90 days. The best results coming from the highest replacement rate of LWA (14 day cure) that yielded 30 and 90 day shrinkage of 220 and 347 microstrain, while the control experienced 313 and 410 microstrain, respectively. When comparing the three different replacement rates, they found the greatest reduction in free shrinkage came in the mixture with the highest amount of LWA used. Their study also found that the addition of LWA had little change on compressive strength.

#### **2.4 Why Use Internal Curing?**

NCHRP Synthesis 333, states that the largest contributing factors to transverse deck cracking are weather and curing (National Cooperative Highway Research Program, 2004). Higher cracking was reported with lower humidity levels and increased evaporation rates. When adverse weather conditions and less than ideal curing methods are experienced in the field, internal curing can be another way to provide the moisture needed to reduce potential cracking. Internal curing should not be used to replace external curing methods, but be used to supplement current curing practices.

Bridge decks experience some of the worst environmental conditions. Most bridge decks are exposed to de-icing salts, freeze-thaw cycles, wet and dry conditions, and thermal variations (Holm, Bremner, & Newman, 1984). Holms used scanning electron micrographs to evaluate cored concrete samples taken from various aging structures located in areas with harsh environment conditions. Holms took concrete samples from structures built as far back as 1919. The samples revealed a very strong bond between LWA and cement paste matrix. He explained that since there is moisture exchange between LWA and the cement paste while the concrete is still in its plastic stage, it prevents a film of water from developing at the aggregate-cement paste interface. The absence of this water layer strengthens that bond. Holms found less micro-cracks at the interface of the LWA and the paste. He concludes that since the elastic stiffness of the LWA is closer to the stiffness of the cement, when compared to normal weight aggregate, the similarities in stiffness decrease concentrations at this interface reducing the amount of micro-cracks. Less micro-cracking results in less outside environment infiltration into the concrete, which increases the service life of structures.

## **2.5 Effects of Internal Curing on Properties of Concrete**

### **2.5.1 Compressive strength**

Internal curing can have a dual effect on concrete compressive strength of concrete. On one hand, the lower strength of LWA can cause an overall decrease in compressive strength in the concrete. However, the increased degree of hydration of the cement paste due to an increase in the available amount of internal water increases concrete compressive strength. Mixture proportioning plays a significant role in concrete strength, so internal curing may have different effects based on the types and amounts of materials used for a particular mixture. The age of testing can also a factor. At early ages, while cement is still in the early stages of curing,

compressive strength may be lower than conventional concrete mixtures due to the mechanically weaker LWA. As the time after casting increases, the internally cured mixtures may continue to cure the concrete at a higher rate than conventional concrete mixtures resulting in increased compressive strengths (Bentz & Weiss, 2011). However, it is important to note that both increases and decreases in compressive strength with the addition of LWA have been found in past research.

### 2.5.2 Modulus of Elasticity

LWA possesses a lower modulus of elasticity than of normal weight aggregate, coarse or fine. When either a portion or total amount of normal weight aggregate is replaced with LWA, the modulus of elasticity of the concrete will decrease in many cases (Byard B. E., 2011). ACI 318 states that modulus of elasticity for concrete is sensitive to the modulus of elasticity of the aggregate (ACI, 2008). It calculates the modulus of elasticity of concrete using Equation 1.

$$\text{---} \quad \text{(Equation 1)}$$

Where:

$E_c$  = Modulus of elasticity for concrete

$w_c$  = unit weight of concrete (lb/ft<sup>3</sup>)

$f'_c$  = compressive strength of concrete (psi)

Replacing normal weight aggregate with LWA will decrease the density of concrete, in turn, reducing the modulus of elasticity as shown in the above equation.

### 2.6 Types of Concrete Shrinkage

It should first be noted that while strains in many cases refer to a volume reduction, strains can also result in volumetric expansion. While ‘shrinkage’ is commonly used in reference to strains, keep in mind that both shrinkage and expansion may occur. Concrete shrinkage can be attributed to multiple causes. Shrinkage causes the internal tensile stresses to increase. Shrinkage

stresses are developed internally and are not caused by external loadings. Once these stresses exceed the tensile capacity of the concrete, cracking will occur. If one can keep concrete shrinkage to a minimum, then the result should be reduced cracking. Plastic, autogenous and chemical, and drying shrinkage will be discussed in further detail.

### **2.6.1 Plastic Shrinkage**

ACI defines plastic shrinkage as “shrinkage that takes place before cement paste, mortar, grout, or concrete sets” (ACI, 2010). Immediately after placement of concrete, the surface begins to lose moisture to evaporation. As the moisture is lost to the environment, the water is transported to the surface from inside the concrete (Henkensiefken, Briatka, Bentz, Nantung, & Weiss, 2010). If the evaporation exceeds the rate at which concrete can supply moisture to the surface, then stresses increase and cracking can occur.

#### **2.6.1.1 Phases of Plastic Shrinkage**

Concrete that is in a drying environment progresses through three drying phases (Lura, Pease, Mazzotta, Rajabipour, & Weiss, 2007). In phase 1 the concrete goes through sedimentation, where the denser particles such as cement and aggregate settle to the bottom. This causes the less dense particles such as the water to rise to the surface. Sedimentation leaves this water at the surface susceptible to evaporation. In Phase 2 the water at the surface begins to evaporate leaving a liquid-vapor menisci that develops capillary pressure which furthers the consolidation process, forcing more water to the surface of the concrete. When concretes contain prewetted LWA, water is drawn out of these reservoirs first, because the pore structure of the LWA is usually larger than those in the cement paste (Henkensiefken, Briatka, Bentz, Nantung, & Weiss, 2010). As this rearrangement of particles continues, there comes a point where the pressure of the concrete matrix cannot be reduced any further, drying of the matrix then

infiltrates in the interior of the concrete. This increases the cracking potential in the concrete and this transition is called the ‘critical point’ (Lura, Pease, Mazzotta, Rajabipour, & Weiss, 2007). This is the point at which the concrete is most susceptible to cracking. During Phase 3 the drying penetrates into the interior of the matrix where the liquid path between the surface and interior disappears. During this phase, the settlement and evaporation rates decrease (Holt, 2001).

### **2.6.1.2 Factors Contributing to Plastic Shrinkage**

Plastic shrinkage is attributed to four major forces (Lura, Pease, Mazzotta, Rajabipour, & Weiss, 2007). First is rapid evaporation of water from the surface of the concrete, which increases the tensile stresses in the capillary water close to the surface. The amount of exposed surface area in relation to the total volume (known as the surface area to volume ratio) will affect the amount of plastic shrinkage that occurs. Bridge decks have a high surface area to volume ratios which can result in plastic shrinkage cracking if preventative measures are not taken. The second force is differential settlement. Areas in contact with reinforcing steel or other restraints will affect the amount of settlement that occurs. The difference in the amount of settlement throughout the concrete specimen will incur tensile stresses which increase the probability of cracking. Concrete mixtures with low slump are less susceptible to plastic shrinkage cracking due to a decrease in settlement (Qi, Weiss, & Olek, 2003). This was confirmed by this research experiences in analyzing plastic shrinkage cracking in thin concrete slabs (Refer to Ch. 4 for details). The third contributing force for plastic shrinkage cracking is differential thermal dilation where a temperature gradient develops between the surface and the inner core of the concrete specimen due to evaporation of the surface water. This temperature gradient will cause differential shrinkage throughout the specimen promoting cracking. When testing for plastic shrinkage cracking in laboratory settings, thin concrete slabs are used to reduce the temperature

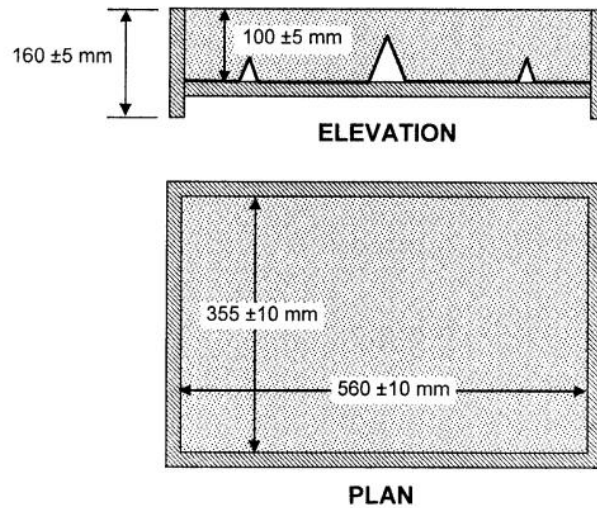
gradient between the surface and the interior of the concrete. The fourth force is autogenous shrinkage before hardening of the concrete matrix. As explained in the following section, hydration results in liquid-vapor menisci which induce tensile stresses. This has also been shown to occur even if evaporation is prevented (Lura, Pease, Mazzotta, Rajabipour, & Weiss, 2007).

### 2.6.1.3 Test Methods for Plastic Shrinkage

Since plastic shrinkage cracking occurs before or during the initial setting of the concrete, methods to assess plastic shrinkage measure the quantity of surface cracking. Quantification of plastic shrinkage cracking has proved difficult in past research. One major factor in concretes' susceptibility to plastic shrinkage is the rate of evaporation. Water loss of  $1.0 \text{ kg/m}^2/\text{h}$  ( $0.2 \text{ lb/ft}^2/\text{h}$ ) has been widely referenced as the evaporation rate that leaves concrete susceptible to plastic shrinkage (ACI, 1999).

*ASTM C1579 Standard Test Method for Evaluating Plastic Shrinkage Cracking of Restrained Fiber Reinforced Concrete (Using Steel Form Insert)* is one method for quantifying plastic shrinkage cracking (ASTM, 2006). This method uses a steel form insert that is fabricated to reduce concrete slab thickness which induces concentrated stresses which can lead to cracking. Since plastic shrinkage cracking can occur in different locations on the surface of the slab, this test method aims at controlling that variability by reducing the thickness of the slab in the transverse direction. This test method was used by Henkensiefken et al. to analyze the effects of internal curing on cement paste and concrete mixtures (Henkensiefken, Briatka, Bentz, Nantung, & Weiss, 2010). Figure 2.2 shows the geometry of the formwork and the steel insert.

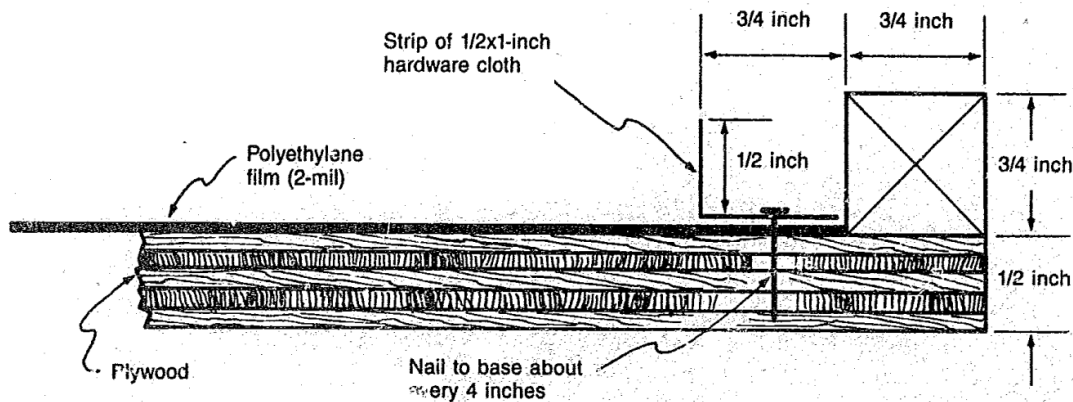




**Figure 2.2 ASTM C 1579 Formwork and Stress Riser Geometry (ASTM 2006)**

This test method is one of the few standardized test methods (and the only ASTM standard) that specifically analyzes plastic shrinkage cracking in concrete. Difficulty arises when trying to analyze plastic cracking in concrete due to the internal restraint of the aggregate. The presence of aggregate causes concrete to shrink less than cement paste (Pelisser, da S. Santos Neto, La Rovere, & de Andrade Pinto, 2010). This is why multiple test methods that analyze plastic shrinkage remove the coarse aggregate by wet sieving which promotes more shrinkage. The higher surface area to volume ratio that exists, the greater the probability that drying and/or plastic shrinkage can occur. This is why bridge decks, pavement surfaces, walls, and large slab floors are more susceptible to this shrinkage cracking (Weiss, Yang, & Shah, 1998).

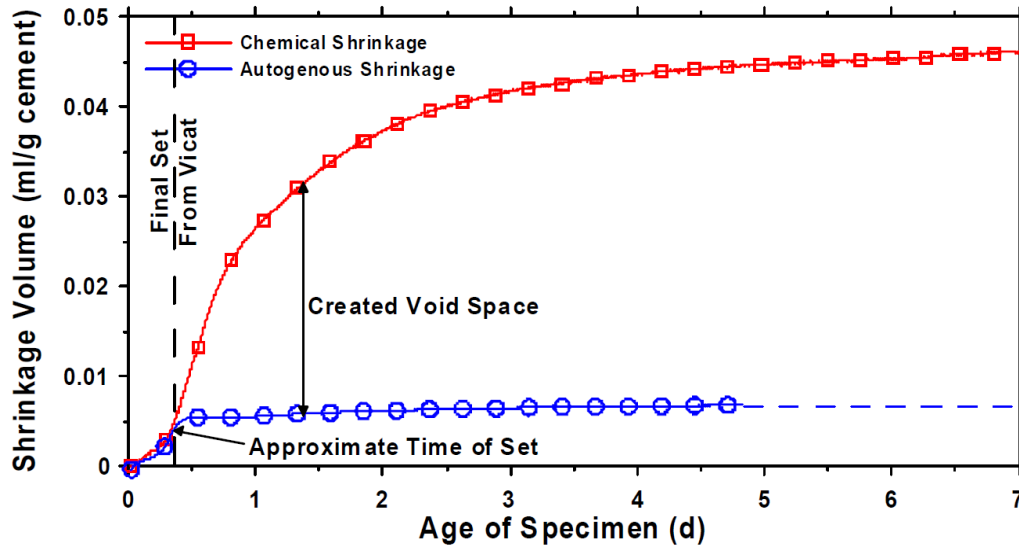
In 1985, Kraai proposed a test to determine the cracking potential attributed to drying shrinkage (Kraai, 1985). This test differed in that it evaluated the cracking potential of specimens at very early ages and results were recorded 24 hours after placement. While Kraai referred to the volume change as drying shrinkage, it should be noted that plastic shrinkage plays a large role in this test. To increase the shrinkage, Kraai evaluated 2 x 3 foot slabs that were  $\frac{3}{4}$  inches thick. This high surface area to volume ratio allows for maximum exposure to the environment. In order to maximize the cracking potential, external restraint was used in the form of wire mesh placed around the perimeter of the rectangular molds (Figure 2.3). The wire mesh restrains the mortar mixture as it shrinks, inducing tensile stresses throughout the slab. Once these stresses exceed the tensile capacity of the mortar mixture, the slabs will crack. Coarse aggregate was not used in this test in order to reduce the amount of internal restraint of the mixture. In the absence of stiff aggregate, the mixture will shrink at a greater rate. The slabs are exposed to high temperature, low humidity and a constant wind speed in order to simulate drying conditions. At 24 hours, crack lengths and widths are evaluated. Shaeles and Hover used Kraai's test method in evaluating the influences of mixture proportions and finishing on plastic shrinkage in cement mortars (Shaeles & Hover, 1988). This research found that reducing the paste volume through the use of water-reducing agents reduced plastic shrinkage cracking. It was also concluded that screeding and finishing played a significant role in the severity of plastic shrinkage cracking. It was stated that it may be possible to use this method to evaluate concrete's potential for plastic shrinkage cracking. The research program used Kraai's methods as the basis for analyzing plastic shrinkage cracking in concrete slabs.



**Figure 2.3 Formwork for Thin Slabs (Kraai, 1985)**

## 2.6.2 Autogenous and Chemical Shrinkage

Autogenous shrinkage is “the bulk strain of a closed, isothermal, cementitious material system not subjected to external forces” (Jensen & Hansen, 2001). The external shrinkage that occurs without the influence of any external forces such as evaporation or temperature changes is autogenous. During the first hours after mixing, autogenous shrinkage is directly related to chemical shrinkage, that is, chemical and autogenous shrinkage are the same. As the concrete hardens, autogenous shrinkage and chemical shrinkage are no longer linked. The solidification of the cementitious matrix no longer allows the autogenous shrinkage to keep pace with ongoing chemical shrinkage (Figure 2.4). After the initial hardening of the cement paste, the autogenous shrinkage is inhibited which decreases the shrinkage of the bulk specimen. The chemical shrinkage continues to increase at this point, creating void space within the cement paste.



**Figure 2.4 Chemical and Autogenous Shrinkage Volumes During Hydration of a Paste with a w/cm of 0.30 (Henkensiefken, 2008)**

The result is a pressure drop in the water that causes vapor-filled cavities in the pore system (Henkensiefken, Bentz, Nantung, & Weiss, 2009). Through the continued process of hydration, water is consumed and the relative humidity inside the concrete can drop. This localized drying due to the drop in relative humidity is called self-desiccation (Holt, 2001). Self-desiccation is a greater cause for concern in lower w/cm concretes. This is due to the fact that with a lower amount of water/ higher amount of cement, there may not be enough water to fully hydrate the cement. So when the water is consumed, the empty pores develop tensile stresses which can cause cracking in the concrete. Autogenous shrinkage increases with increasing cement content, cement fineness, and temperature (ACI, 2001).

The reactions between cement and water result in chemical shrinkage, which causes a reduction in volume (Holt, 2001). Chemical shrinkage is “the volume reduction associated with the hydration reactions in a cementitious material” (Jensen & Hansen, 2001). The volume of the hydration products is less than the sum of the individual volumes of water and cement.

### 2.6.2.1 Testing Methods for Autogenous Shrinkage

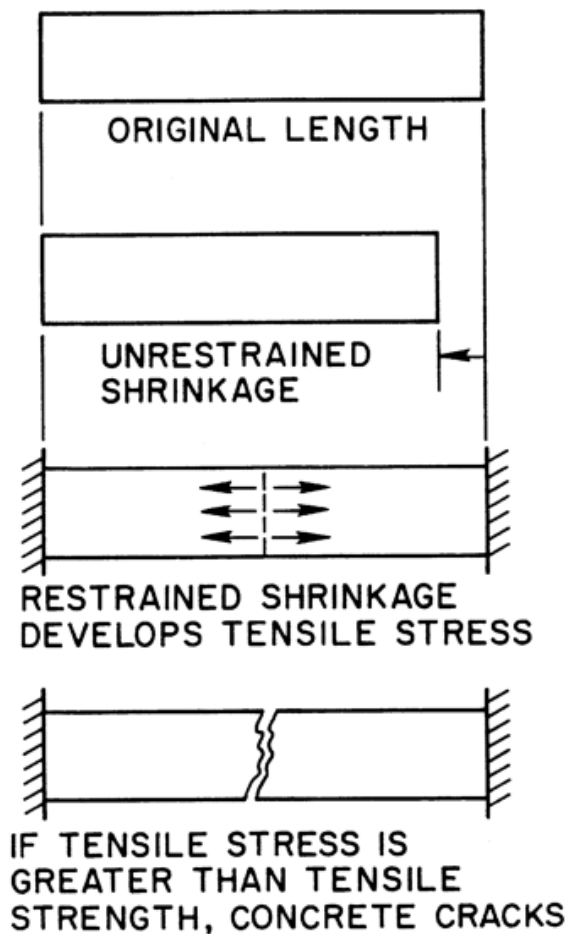
Testing concrete or cement paste specimens in sealed conditions is a way of measuring autogenous effects. By eliminating drying shrinkage, it can be assumed that the shrinkage that does occur under sealed conditions is autogenous. There are multiple methods to assess autogenous shrinkage. For mortar and paste specimens, ASTM C1698 *Standard Test Method for Autogenous Strain of Cement Paste and Mortar* is predominately used. The mixture is placed in a corrugated tube that is sealed. The corrugated tubes cause the mixture to only expand at the two ends that are not restrained. The contraction or expansion at the two ends is measured after setting by two linear variable differential transformers (LVDT) (ASTM, 2009).

For concrete and mortar specimens, sealed prisms have been studied to evaluate autogenous effects. Weiss, Borischevsky, and Shah used sealed prisms to evaluate autogenous effects on high performance concrete in 1999. Another test method is ASTM C1581 *Standard Test Method for Determining Age at Cracking and Induced Tensile Stress Characteristics of Mortar and Concrete under Restrained Shrinkage*. This test method evaluates autogenous effects by monitoring shrinkage cracking under restrained conditions. (Bentz & Weiss, 2011).

### 2.6.3 Drying Shrinkage

Drying shrinkage is a volume reduction from a loss of water in concrete (Holt, 2001). As the concrete dries, water is emptied out of internal pores causing them to shrink, reducing the volume of the concrete specimen. Drying shrinkage occurs when concrete is in its hardened state. Reduction of the free water in concrete is due to several factors. External factors such as wind and temperature can increase the surface evaporation which draws free water from inside the concrete. Internal factors, such as hydration, chemically consume the free water thus further drying the concrete.

When concrete shrinks the tensile strain increases. If the concrete tensile strain exceeds the tensile strain capacity of concrete, then cracking will occur. Concrete used in structural application is generally restrained in some way. Restraint refers to external materials in contact with concrete that limit the extent to which the concrete contracts. When concrete shrinkage and restraint are combined, tensile stresses are developed (ACI, 2001). Examples of restraint can be foundations, reinforcing steel, other sections of the structure, or geometry. Figure 2.5 illustrates how tensile stresses are developed with the combination of drying shrinkage and restraint.

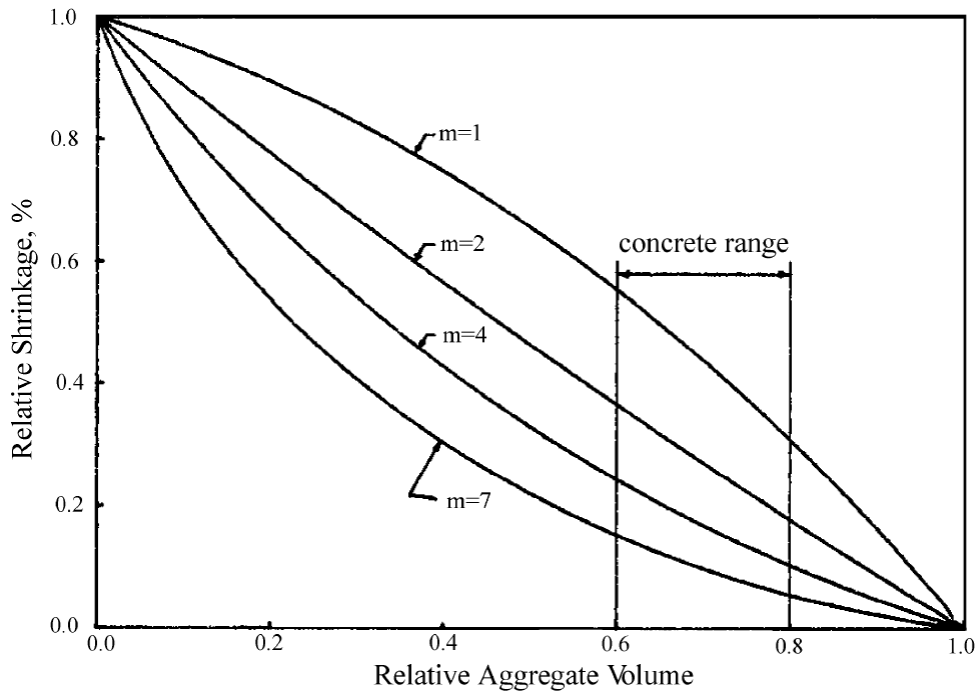


**Figure 2.5 Concrete Cracking Due to Drying Shrinkage (ACI, 2001)**

### 2.6.3.1 Factors Contributing to Drying Shrinkage

The main factors controlling drying shrinkage of concrete include relative humidity, aggregate type, aggregate content, water content, and w/cm (ACI, 2001). As the relative humidity increases, the drying shrinkage decreases (Hansen & Almudaiheem, 1987). In their testing of cement paste with a w/cm of 0.60, Hansen & Almudaiheem found ultimate drying shrinkage in the cement paste equal to 1.00 percent at a relative humidity of zero percent and an ultimate drying shrinkage in the paste of 0.10 percent at a relative humidity of 90 percent. This study shows how significant a role relative humidity plays on the drying shrinkage of concrete.

Both the type and quantity of aggregate affect the amount of drying shrinkage. As mentioned above, cement and water react through hydration which reduces the volume of the cement-water paste. Coarse aggregate reduces the amount of shrinkage in the paste through the aggregate's elastic restraint (ACI, 2001). The highly rigid rock acts as internal restraints which fight against the shrinkage of the paste. Another factor affecting the amount of drying shrinkage is the modulus of elasticity of the coarse aggregate. Past studies have shown that as the modulus of elasticity of the aggregate increases, the linear shrinkage of concrete decreases (Hansen & Almudaiheem, 1987). Figure 2.6 shows how both the quantity and the type of aggregate influence the relative shrinkage of concrete. Note that 'm' refers to the modulus ratio, which is the ratio of the modulus of elasticity of the aggregate to the modulus of elasticity of the fully hydrated cement paste. From the figure one can observe that both aggregate content and type have a major influence on drying shrinkage of concrete.



**Figure 2.6 Effect of Relative Aggregate Content and Modulus Ratio on Drying Shrinkage of Concrete (Hansen & Almudaiheem, 1987)**

For a fixed w/cm, an increase in water content (which also increases the cement content) increases drying shrinkage. If the aggregate size or content of a concrete mixture change, then the cement paste volume may have to be altered in order to obtain similar consistency. Smaller aggregate size increases surface area that needs to fully coated by the cement paste in a given mixture. Therefore, if a targeted consistency, which is measured by slump, is required, then using larger aggregate size may require less cement paste for coverage which will also decrease the amount of drying shrinkage that occurs. As the w/cm increases, so does the shrinkage (ACI, 2001).

### 2.6.3.2 Test Methods for Drying Shrinkage

The most widely used method for evaluating drying shrinkage in concrete and cement mortar specimens is ASTM C157 *Standard Test Method for Length Change of Hardened*



*Hydraulic-Cement Mortar and Concrete* (ASTM, 2008). This method measures the linear length change of concrete specimens exposed to drying conditions from 24 hours after casting. The length change of a prism cast with concrete or cement mortar is measured by a length comparator (Figure 2.7). The shrinkage is recorded beginning at 1 day of age and all of the remaining shrinkage values are compared to the 1 day length. For each testing period, the prisms are measured, and the change in length divided by the original length of the prism yields the linear strain which is the amount of drying shrinkage. The method can be done at a relatively low cost compared with other methods in evaluating shrinkage in concrete or cement mortars.



**Figure 2.7 Linear Comparator and Prism used in ASTM C157**

## **2.7 Lightweight Aggregate**

As noted earlier in Section 2.1, naturally formed LWA's were used in concrete thousands of years ago. While naturally forming LWA such as pumice and scoria can be used in concrete, its variability and selective deposit locations make it unrealistic for global use. Today, the majority of LWA is manufactured. There are various manufacturing methods including rotary kiln heating, sintering, and molten slag agitation (ACI, 2003). The research discussed herein

focused on the use of LWA's manufactured in rotary kilns and so will be the focus in this literature review.

### **2.7.1 Manufacturing LWA**

The process of manufacturing LWA started with Stephen Hayde's 1914 patent. He later discovered that a rotary kiln could be used to efficiently produce the LWA (Bremner & Ries, 2009). The manufactured LWA comes from heating clay, shale, or slate that passes through in a long, inclined, cylindrical kiln that continually rotates. Temperatures gradually increase for the first two-thirds of the kiln, and then quickly increase for the remaining one-third of the kiln (Byard & Schindler, 2010). Maximum temperatures can reach almost 2200 degrees Fahrenheit (F). See Figure 2.8 for an illustration of the process of manufacturing expanded clay, shale, and slate. At these extreme temperatures, the material becomes plastic while gases from the interior are released causing expansion. These gases form disconnected pores throughout the aggregate structure once the material cools and becomes elastic. The formation of pores in the aggregate decreases the density of the aggregate. These internal pores are able to hold water until the cement paste requires it.

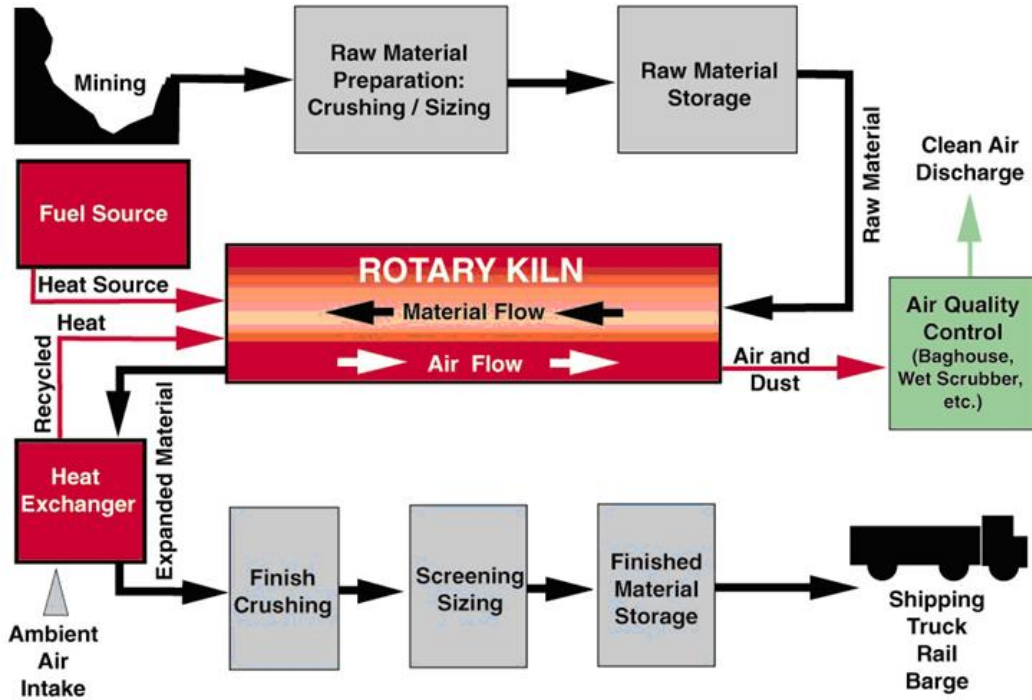


Figure 2.8 Manufacturing Process of Expanded Clay, Shale, and Slate (Byard & Schindler, 2010)

### 2.7.2 Mixture Proportioning of LWA

Mixture proportioning the correct amount of LWA is an important step to insure that there is a sufficient amount of internally stored water to increase hydration. Bentz and Snyder developed an equation to estimate the amount of fine LWA needed for internal curing (Bentz, Lura, & Roberts, 2005). Even though the equation is intended for the use of fine LWA, it was used as a guide for determining the approximate amount of coarse aggregate needed.

(Equation 2)

Where:

= mass of dry, fine LWA (lb/yd<sup>3</sup>);

= cement factor or content for the concrete mixture (lb/yd<sup>3</sup>);

CS = chemical shrinkage of cement (g of water/g of cement);

- = maximum expected degree of hydration of cement;
- S = degree of saturation of cement (0 to 1);
- = absorption of lightweight aggregate (g of water/g of dry LWA);

For w/cm below 0.36, using (w/cm)/0.36 gives the estimated maximum degree of hydration of the cement ( ). If the w/cm is above 0.36, then the maximum degree of hydration is assumed to be 1.0. The chemical shrinkage of cement (CS) will vary depending on the type of cement used in the mixture. Bentz et al. calculated the coefficients for chemical shrinkage shown in Table 2.1. He notes that the coefficients for chemical shrinkage can vary significantly based on the densities chosen for the different phases of cementitious materials, but the values given below are used in the Virtual Cement and Concrete Testing Laboratory system (Bentz, Lura, & Roberts, 2005).

**Table 2.1 Calculated coefficients for Chemical Shrinkage Due to Cement Hydration (Bentz, Lura, & Roberts, 2005)**

Cement Phase	Coefficient, g water/g solid cement phase
C <sub>3</sub> S	0.0704
C <sub>2</sub> S	0.0724
C <sub>3</sub> A	0.171* 0.115**
C <sub>4</sub> AF	0.117* 0.086**
Silica Fume	0.20

\* Assuming sufficient sulfate to convert all of the aluminate phases to ettringite

\*\* Assuming total conversion of the aluminate phases to monosulfate

Equation 2 estimates how much curing water is needed to maintain total saturation in the cement paste by compensating for the chemical shrinkage in the cement paste at the maximum estimated degree of hydration of cement (Bentz, Lura, & Roberts, 2005). Whether internal curing is used for a low or high w/cm concrete, steps should be taken to prevent evaporation of water

from the surface of the concrete. Higher w/cm concretes will be more susceptible to increased evaporation due to the increased amount of bleed water at the surface.

## **2.8 Summary**

As highlighted in this literature review, shrinkage of concrete can negatively affect the service life of structures by inducing early age cracking. Reinforcing steel can provide restraint to concrete shrinkage which increases tensile stresses that lead to cracking if the tensile capacity of concrete is exceeded. These cracks can leave concrete susceptible to adverse environmental conditions which increase the deterioration rate of the structure. Internal curing is a method that reduces concrete shrinkage by providing internally stored water, via LWA, to be cured as needed throughout the hydration process. While most of the past research of internal curing has focused on HPC (containing a low w/cm), the continuing use of conventional concrete in bridge decks and other structural applications demands research to mitigate shrinkage cracking in concretes that maintain normal w/cm.

## **Chapter 3 Experimental Procedures**

### **3.1 Purpose**

The purpose of the laboratory study was to test and evaluate the effect that coarse LWA has on concrete shrinkage. The study was broken into two phases: first, to study the effects of coarse LWA on the drying shrinkage from casting to 112 days of age; second, to study the effects of coarse LWA on reducing plastic shrinkage cracking in concrete slabs at early ages. The research also evaluated the effectiveness of coarse LWA on the concrete mixtures adherence to the Arkansas State Highway and Transportation Department (AHTD) specifications. This research differed from the majority of internal curing research in that internal curing was evaluated in a conventional concrete mixture. As stated in the Literature Review, past research has found that internal curing may not be needed in conventional concrete mixtures in ideal curing conditions. Even with conventional concrete mixtures, many Department of Transportation's (DOT's) still experience shrinkage cracking in bridge decks. In summary, the purpose of this research was to evaluate the effectiveness of internal curing when conventional concrete is subjected to drying conditions in both plastic and hardened states.

### **3.2 Materials**

#### **3.2.1 Mixtures**

The hardened concrete properties were examined for seven different mixtures. A control mixture was batched using normal-weight coarse aggregate (Control). The control mixture was prepared to conform to Section 802 of the AHTD Standard Highway Specifications for a Class S(AE) concrete. A minimum cement content of 611 lb/yd<sup>3</sup> of Type I portland cement was required. A fraction may be replaced by supplementary cementitious materials. The maximum w/cm permitted was 0.44, and the minimum 28 day compressive strength was 4000 psi.

For three mixtures a portion of the coarse aggregate was replaced with Expanded Clay LWA by amounts of 100, 200, and 300 lb/yd<sup>3</sup> (Clay1, Clay2, and Clay3, respectively). In the three remaining mixtures, a portion of the coarse aggregate was replaced with Expanded Shale LWA at the same replacement rates as shown above (Shale1, Shale2, and Shale3, respectively). All mixtures contained 1700 lb/ yd<sup>3</sup> of coarse aggregate (normal weight plus LWA) (Table 3.1).

**Table 3.1 Mixture Proportions**

Mixture	Unit Weight per Unit Volume (lb/yd <sup>3</sup> )					
	Cement	Coarse Aggregate	LWA	Sand	Water	w/c
Control	611	1700	0	1440	269	0.44
Clay1	611	1600	100	1329	269	0.44
Clay2	611	1500	200	1218	269	0.44
Clay3	611	1400	300	1107	269	0.44
Shale1	611	1600	100	1353	269	0.44
Shale2	611	1500	200	1266	269	0.44
Shale3	611	1400	300	1178	269	0.44

### 3.2.2 Cementitious Material and Admixtures

In all mixtures, Type I portland cement was used. In order to eliminate variables that could contribute to the overall shrinkage, supplementary cementitious materials were not included. In order to achieve a slump of 1-4 inches as required by AHTD, a superplasticizer, ADVA Cast 575, was used in all mixtures. The amount of the superplasticizer varied occasionally in order to maintain the specified slump.

### 3.2.3 Normal-weight Coarse Aggregate

The coarse aggregate used in the Control mixture was crushed limestone obtained from McClinton-Anchor located in Springdale, AR. The coarse aggregate complied with grading requirements of AASHTO T 27 (Table 3.2).

**Table 3.2 Limestone Gradation**

Sieve Size	AHTD Specification, Coarse Aggregate % Passing
1.25"	100
1.0"	60-100
0.75"	35-75
0.5"	-
0.375"	10-30
#4	0-5
#8	-

### 3.2.4 Fine Aggregate

The fine aggregate used was dredged river sand from the Arkansas River. The fine aggregate complied with AASHTO T 27 (Table 3.3).

**Table 3.3 Fine Aggregate Gradation**

Sieve Size	AHTD Specification, Fine Aggregate % Passing
0.375"	100
#4	95-100
#8	70-95
#16	45-85
#30	20-65
#50	5-30
#100	0-5

### 3.2.5 Coarse Lightweight Aggregate (LWA)

Two different types of coarse LWA were used during testing, expanded clay and expanded shale. The coarse expanded clay was manufactured in West Memphis, AR by Old Castle Materials Inc. The coarse expanded shale was manufactured in Ottawa, KS by Buildex Inc. The properties of the coarse aggregate used in this research are shown in Table 3.4.



**Table 3.4 Coarse Aggregate Properties**

Coarse Aggregate	Absorption Capacity (Percent)	Specific Gravity
Crushed Limestone	0.38	2.68
Expanded Clay	15.0	1.25
Expanded Shale	12.9	1.41

Absorption capacities and specific gravities were tested in previous research performed by Royce Floyd at the University of Arkansas (Floyd, 2012). The crushed limestone which was used in the control mixture is included to contrast its properties with those of the coarse LWA's. The expanded clay LWA had a nominal maximum aggregate size of ½ inch, and the expanded shale LWA had a nominal maximum aggregate size of ¾ inch. Figure 3.1 shows both types of coarse LWA used in this study.



**Figure 3.1 Expanded Clay LWA (left) and Expanded Shale LWA (right)**

### **3.3 Phase I - Drying Shrinkage Testing**

Phase I of the research project involved testing the effects of internal curing on drying shrinkage. Preliminary tests were performed analyzing different mixture proportions and their influence on drying shrinkage. Drying shrinkage was measured using methods specified in

ASTM C157 (ASTM, 2008). For each test batch, four prisms were cast and tested. Compressive strength was tested up to 56 days. When it was determined that the internally cured mixtures showed less shrinkage using ASTM C157 test method, all mixture proportions shown in Table 3.1 were again batched in the same molds. However, during this phase of the investigation VWSG were embedded to monitor temperature and strain from the period immediately after casting to 112 days. Due to the cost of the VWSG, ASTM C157 was used first to establish that a reduction in shrinkage was occurring. This allowed the mixture proportions and procedures to be modified to ensure that internal curing was taking place before implementing testing with the VWSG. Compressive strength tests were again administered for all mixtures.

### **3.3.1 Mixing Procedure and Aggregate Preparation**

The LWA was placed in an oven at 330 degrees Fahrenheit approximately 48 hours before mixing to remove all moisture from the aggregate. After 24 hours in the oven, the LWA was removed and allowed to cool to room temperature. The LWA was placed into 5 gallon buckets and saturated in water approximately 24 hours prior to mixing. At this time, samples of the normal weight rock and sand were placed into the oven to determine moisture content.

Immediately prior to mixing, the buckets containing the LWA were drained of excess water. This was done by placing a lid with small holes on the bucket and turning over to drain. After allowing the excess water to drain, the LWA was weighed and a sample was taken and placed into the oven to determine actual moisture content. Since the LWA had to be saturated in water for 24 hours prior to mixing, it was necessary to assume the moisture content of the LWA based on prior testing. Shown in Tables 4.3 and 4.7 in Chapter 4 are the assumed and actual moisture contents of both clay and shale LWA. Moisture contents for the normal weight fine and coarse aggregate were calculated, and the amount of mixing water was adjusted based on those

moisture contents. ADVA Cast 575 superplasticizer was added directly to the mixing water to achieve the desired slump.

For drying shrinkage testing, mixtures were batched into a 9.0 ft<sup>3</sup> capacity electric rotating drum mixer (Figure 3.2). Each mixture volume was 2.5 ft<sup>3</sup>. The inside of the rotating mixer was wetted prior to mixing. All coarse aggregate and half of the mixing water were added first and mixed. The remaining water, fine aggregate, and cement were then added and mixed for approximately three minutes. The fresh concrete was allowed to rest for approximately three minutes and a slump test was administered. The concrete was mixed again and poured into a wheel barrel prior to casting.



**Figure 3.2 Rotating Drum Mixer**

### **3.3.2 ASTM C157- Linear Length Change**

Linear shrinkage was first tested using ASTM C157. The steel molds and linear comparator were used in accordance with ASTM C490 (ASTM, 2004). Steel molds

manufactured by Humboldt were used. The specimens measured 4 x 4 x 10 inches. Gage studs were embedded in to each end to the concrete specimens. The specimen molds are shown in Figure 3.3.



**Figure 3.3 Steel Molds**

Linear shrinkage of the specimens was measured using a length comparator with digital indicator manufactured by Humboldt (H-3250) (Figure 3.4). Measurements were accurate to 1/10,000 of an inch. Four prisms were cast for each mixture, and the length of each prism was measured twice at each age.



**Figure 3.4 Length Comparator with Digital Indicator ([www.humboldtmg.com](http://www.humboldtmg.com))**

### **3.3.2.1 Casting and Curing Procedures**

The prisms were cast in accordance with ASTM C157. After mixing, concrete was placed into the steel molds. The inside surfaces of the steel molds were oiled to facilitate demolding. Concrete was placed in two layers. Each layer was rodded 22 times, and the sides of the molds were tamped with a rubber mallet to released internal air voids. The surfaces of the prisms were finished with a steel trowel. The molds holding the fresh concrete were immediately placed in an environmental chamber with a relative humidity of  $50 \pm 4$  percent at a temperature of  $73 \pm 3$  degrees Fahrenheit ( $23 \pm 2$  degrees Celsius). The environmental chamber adhered to ASTM C511 (ASTM, 2009b). The relative humidity was controlled using a dehumidifier. The

specimens were demolded, and the first measurement was recorded at  $23.5 \pm 0.5$  hr. After testing, prisms were placed on wooden rollers so to not inhibit shrinkage of the specimens and to allow proper air circulation to all sides of the prisms while in the environmental chamber.

### **3.3.2.2 Linear Shrinkage Recording**

Shrinkage was recorded at 1, 7, 14, 21, 28, 56, 90, and 112 days for each of the four prisms cast with each experimental mixture. First, the reference bar was measured on the linear comparator and zeroed. Then, the concrete prism was placed on the linear comparator and spun. The length was then recorded. The reference bar was placed back on the comparator and zeroed, and the next prism length was recorded. This process was repeated so that the length of each prism was recorded twice to ensure consistent results. Shrinkage strain was calculated by dividing the change in length by the gage length of 10 inches.

### **3.3.3 Compressive Strength Cylinders**

Twelve 4 x 8 inch cylinders were cast for each mixture in accordance with ASTM C39. The cylinders were cast at the same time as the prisms, and then placed in the environmental chamber. The cylinder molds were capped for the first 24 hours. At  $23.5 \pm 0.5$  hours, the cylinders were demolded and placed into a lime-saturated water tank until time of testing. The cylinders were tested at 1, 7, 28, and 56 days. For each testing period, three cylinders were tested for compressive strength using a Forney hydraulic compression machine (Figure 3.5).





**Figure 3.5 Concrete Testing Machine**

### **3.3.4 Strain Gage Testing- Linear Length Change**

Once the preliminary testing using ASTM C157 showed that internal curing reduced shrinkage, VWSG were used to monitor shrinkage in the concrete specimens. The rationale for using VWSG was three-fold. First, using VWSG allowed monitoring and recording both temperature and strain immediately after concrete was cast into the prisms. This gave insight on the effect the LWA has on set time, shrinkage strain prior to 24 hours, and temperature during initial hydration. Second, it allowed for readings to be taken at closer time intervals and with

greater accuracy. Third, it allowed comparison with ASTM C157 so that implementation of VWSG may be investigated for future use. For each concrete mixture, three prisms were cast, each with one VWSG embedded inside the prism.

#### 3.3.4.1 Casting and Curing Procedures

Casting of the molds used in VWSG testing was similar to the casting procedure used in ASTM C157. The same steel molds were used. The gage studs that were used in ASTM C157 were not used when testing shrinkage with VWSG. The holes that previously contained the gage studs were covered with tape. All of the interior surfaces of the molds were then oiled to make the demolding process easier and limited the restraint due to adhesion of the concrete and the steel mold surfaces. Concrete was cast in two layers. Each layer was rodded 22 times and tapped uniformly on all four sides with the rubber mallet. The VWSG was placed on top of the first layer in the center of the molds (Figure 3.6).

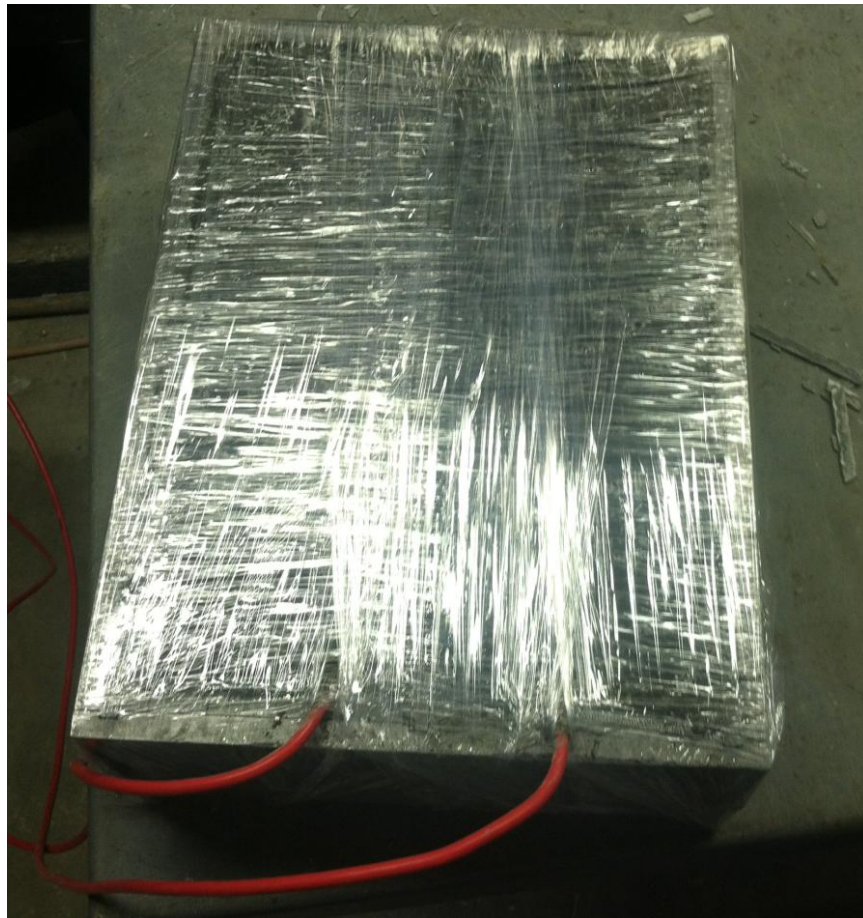


**Figure 3.6 Vibrating Wire Strain Gage Placement in Steel Molds**



The second layer of concrete was placed over and around the VWSG. The layer was gently rodded and the sides of the mold were tapped. The surface was finished using a trowel. Placing and keeping the VWSG centered in the molds was possible due to the high coarse aggregate content of all mixtures.

Immediately after the surfaces of the specimens were finished, they were sealed with industrial grade cellophane wrap (Figure 3.7). The cellophane wrap was used to prevent moisture loss to the environment during the first 24 hours in order to rule out environmental factors during the first 24 hours and limit the types of shrinkage to chemical and autogenous.



**Figure 3.7** Wrapped Steel Molds During First 24 Hours

Once the molds were sealed, they were brought into the environmental chamber. The VWSG were immediately connected to the data acquisition system to begin recording strain and temperature data. The environmental chamber adhered to the same conditions as specified in Section 3.3.2.1.

After  $23.5 \pm 0.5$  hour, the cellophane wrap was removed and the concrete prisms were removed from the molds. The concrete prisms were placed on wooden rollers to allow for free shrinkage and uniform temperature and humidity on all side of the prisms. The prisms remained in the environmental chamber for the remainder of the 112 day testing period (Figure 3.8).

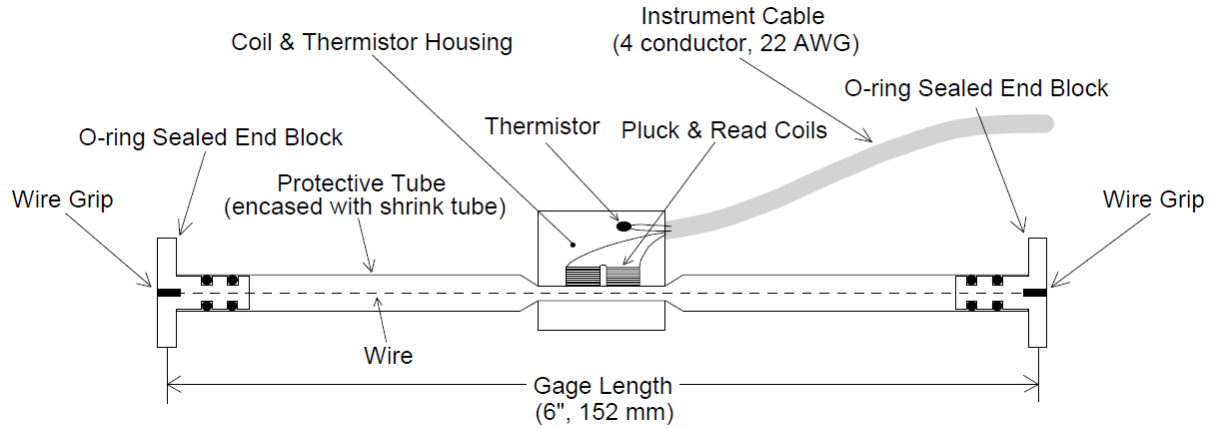


**Figure 3.8 Concrete Prisms**

### 3.3.4.2 Strain Gages and Data Acquisition System

A data acquisition system was developed and programmed to monitor strain and temperature readings during the testing period at specified time intervals. Geokon Model 4200

VWSG were used. This strain gage is designed for direct embedment into concrete and to monitor short and long term strain and temperature (Figure 3.9).



**Figure 3.9 Model 4200 Vibrating Wire Strain Gage (www.geokon.com)**

A Campbell Scientific CR10X datalogger collected strain and temperature readings. The datalogger has a data storage capacity of 128 kilobytes, which translates to a maximum storage of 62,252 data points. Due to the memory size, data were downloaded to a computer throughout the testing period. Campbell Scientific's PC400 datalogger support software was used to program and upload data from the CR10X. There were seven different mixtures tested and three separate prisms (each with one VWSG) for each mixture giving a total of 21 VWSG taking strain and temperature readings. The data acquisition system consisted of 21 VWSG, a CR10X datalogger, two AM416 multiplexors, and one AVW4 vibrating wire interface. A multiplexor allows for multiple sensors to be connected to a single datalogger. Two multiplexors were needed since the AM416 multiplexor was able to read only 16 sensors (when both strain and temperature are being recorded). Therefore, the two multiplexors were wired and programmed to run one, 21 count loop for every time interval. Data for all VWSG were taken every five minutes. At later ages, all data were recorded at one hour intervals.

Before casting the VWSG into the concrete prisms, preliminary tests were performed to verify the accuracy of the strain readings produced by the VWSG and the data acquisition system. The preliminary tests were performed by mounting a VWSG to the top of a steel cantilever arm. Twenty-five (25) pounds was loaded to the end of the cantilever beam. The material and dimensional properties of the cantilever beam were known which allowed calculation of theoretical strain at the location of the VWSG. The VWSG was then connected to a Geokon Model GK403 Vibrating Wire Readout Box which displayed the strain experienced by the VWSG. The difference between the theoretical and measured strain readings in the cantilever test was 4.5 microstrain ( $4.5 \times 10^{-6}$  in/in). Lastly, the Geokon Model GK403 Vibrating Wire Readout Box and the readings taken from the data acquisition system were compared and verified.

When concrete prisms' volume decreased in unrestrained conditions, the strain gages compressed. This yielded smaller strain readings as the prisms continued to shrink throughout the testing period. Therefore, in order to offset all of the strain results showing negative values, all strain values were changed in sign (all positive strain are shown as negative and negative strain shown as positive). As strain values increased (as shown in Figures 4.1-4.11), the shrinkage of the prisms increased.

### **3.4 Phase II - Plastic Shrinkage Testing**

Phase II of the research analyzed the effects of internal curing on plastic shrinkage. As mentioned in the Literature Review, difficulty arises when trying to quantify plastic shrinkage cracking. A high surface area-volume ratio is necessary to aid in plastic shrinkage, which generally stipulates using thin concrete slabs. By using thin slabs the surface area to volume ratio



was maximized. The process and difficulties in assessing plastic shrinkage cracking will be explained further in Chapter 4 Results and Discussion.

### 3.4.1 Mixing Procedure and Aggregate Preparation

The mixing procedure and aggregate preparation for plastic shrinkage testing was very similar to the procedure highlighted in Section 3.3.1. The main difference was the quantity of concrete that was batched for each mixture. In most cases, twelve cubic feet of concrete was batched for each mixture. Due to the increased volume of the mixtures, a one cubic yard gas-engine powered rotating drum mixer was used (Figure 3.10).



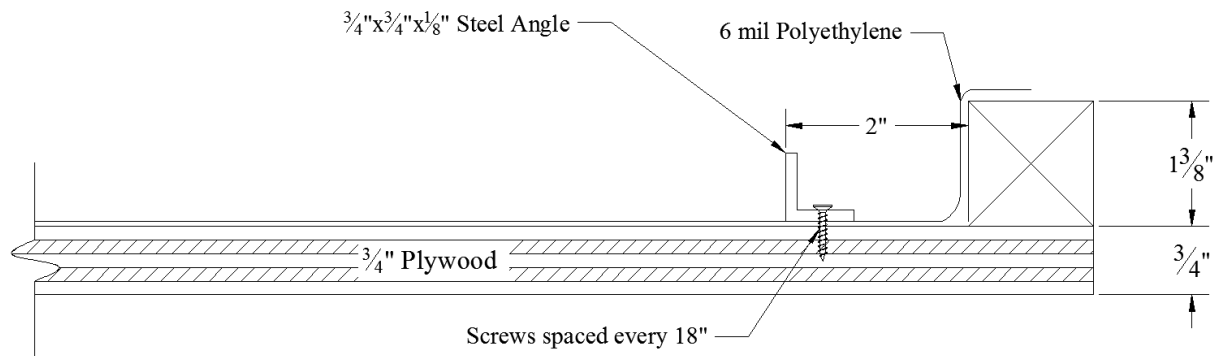
**Figure 3.10 One Cubic Yard Rotating Drum Mixer**

### 3.4.2 Mixtures

In an effort to effectively test and measure plastic shrinkage cracking in concrete, 16 separate mixtures were tested during this phase of the research project. The different mixtures will be discussed further in Section 4.3.

### 3.4.3 Formwork

The dimensions and materials used in the formwork of the thin slabs are as follows. Four by eight foot (4 x 8 ft.) plywood boards,  $\frac{3}{4}$  inch thick, were used as the bottom of the formwork, and  $1\frac{1}{2}$  x  $1\frac{1}{2}$  inch boards (actual dimensions of  $1\frac{3}{8}$  x  $1\frac{3}{8}$  inch) were screwed to the perimeter of the plywood sheet. The  $1\frac{1}{2}$  x  $1\frac{1}{2}$  inch boards made up the sides of formwork and produced the thickness of  $1\frac{3}{8}$  inch. Six mil polyethylene sheeting lined the bottom and sides of the formwork to prevent moisture loss of the fresh concrete by soaking in to the wood formwork. To increase the external restraint of the formwork,  $\frac{3}{4}$  x  $\frac{3}{4}$  x  $\frac{1}{8}$  inch angle steel was used. Holes were drilled approximately every 18 inches in the bottom leg of the angle. That leg was screwed over the polyethylene sheeting to the plywood around the entire perimeter of the formwork. The vertical leg of the steel angle member measured 2 inches from the sides of the formwork (Figure 3.11).



**Figure 3.11 Formwork Details**

### 3.4.4 Casting Procedure

For each mixture, two 4 x 8 ft. slabs were cast. After the desired slump value was obtained, the mixer was moved in position so that the concrete could be placed onto the first slab. The concrete was placed onto the center of the formwork where it was distributed uniformly using shovels. The edge of a 5 ft. long section of plywood was wetted and used to

screed the surface of the slab. The plywood screed was worked by two people longitudinally from one end to the other, creating a level surface. The surface was immediately finished using steel trowels until it was smooth and uniform. A proper finish was necessary to be able to visually locate surface cracks and eliminate surface voids or defects that might cause stress concentrations. The surface was smoothed using steel trowels as quickly as possible, then not disturbed to allow bleed water to evaporate and surface cracks to develop. External vibration was not used. During the preliminary tests, a vibrator was used, but was not effective in consolidating the concrete due to the rock content and the small slab thickness. Therefore, consolidation was performed by compressing the concrete over the entire area of the slab manually using steel trowels.

### **3.4.5 Environmental Conditions**

Due to the size of the slabs, all slabs were cast and tested outdoors (Figure 3.12). While performing laboratory experiments in uncontrolled conditions is not preferable, the time of the year and weather conditions during testing were desirable in creating a drying environment for the slabs. As mentioned in Ch. 2, in order to produce plastic shrinkage cracks, harsh environmental conditions must be maintained. For that reason the slabs were cast and tested in August. The average temperature in August in Fayetteville, AR is 89 degrees F. Mixing began around 1:00 p.m. so that the slabs would be finished during the hottest time of the day. The slabs were cast on days with direct sunlight to increase the evaporation rate. A 3 x 3 ft. box fan was used to increase the wind velocity over the slabs, which also increases the evaporation rate. The fan was turned on immediately after the surface of the slabs were finished and remained on for 4 hours. The rate of evaporation was measured by weighing an evaporation pan filled with water every 30 minutes after finishing. ACI 305 *Hot Weather Concreting* states that an evaporation

rate of 0.2 lb/ft<sup>2</sup>/hr (1.0 kg/m<sup>2</sup>/hr) of water will promote plastic shrinkage cracking on a concrete surface (ACI, 1999). The results of the evaporation rates for each slab are given in Chapter 4. To promote cracking, the slabs were not externally cured.



**Figure 3.12 Environmental Conditions**

### **3.4.6 Crack Measurements**

Test slabs usually experienced initial cracking approximately 30 minutes after finishing the surface. Once cracks began to initiate, the advancement of crack length and width occurred quickly. At approximately 24 hours after finishing the slabs, cracks were assessed. The procedure of quantifying cracking started with tracing all surface cracks with a permanent marker. The lines were not traced directly on the cracks, but were traced adjacent to the cracks. This was done so that the widths of the cracks could be visually determined, and so that the point at which the crack terminated would be correctly identified. The crack ends were marked so that any crack growth subsequent to 24 hours could be determined. After all of the cracks were traced, the crack lengths were measured. This was done using monofilament line. The small



diameter and flexibility of the line allowed the crack lengths to be measured accurately. The monofilament line was marked every two inches with a marker. While measuring the crack lengths, the location of the 2 inch intervals were marked on the slab along the cracks. It was at these two inch marks that crack width measurements were taken. Taking measurements every two inches allowed crack width measurements to be taken in unbiased locations. Crack widths were measured at the same locations at one day and two weeks after casting the slabs. The width of the crack was estimated using a crack width comparator card. This transparent card contained lines with widths from 0.1 mm up to 3 mm. The card was placed directly over the crack and the width at that location was estimated by comparing with the known line widths displayed on the card. Once all of the crack lengths and widths were recorded, total crack area was computed by multiplying the crack length by the average crack width. The total crack area was the result in which the plastic shrinkage cracking was quantified (Figure 3.13).



**Figure 3.13 Test Slab During Crack Measurements**

## **Chapter 4 Results and Discussion**

### **4.1 Phase I: Preliminary Shrinkage Data using ASTM C157**

The research began by assessing the shrinkage of various concrete mixtures using ASTM C157. These results were to verify that a reduction in shrinkage was occurring with the internally cured mixtures. Mixtures were initially batched with 1790 lb/yd<sup>3</sup> of total coarse aggregate. This proportion of rock made it difficult to cast the concrete into the steel prisms. Therefore, the total amount of coarse aggregate was reduced to 1700 lb/yd<sup>3</sup>. The results below are from the preliminary tests using 1700 lb/yd<sup>3</sup> of coarse aggregate.

#### **4.1.1 Mixture Proportions**

Four different mixture proportions were used in the preliminary shrinkage results. The ‘ControlP’, ‘Clay1P’, ‘Clay2P’, ‘Clay3P’, and ‘Shale3P’ contained: 0, 100, 200, and 300 lb/yd<sup>3</sup> of expanded clay LWA; and 300 lb/yd<sup>3</sup> of expanded shale LWA, respectively. The ‘P’ denotes that these mixtures were preliminary mixtures, so not to be confused with the mixtures tested using the embedded VWSG. The mixture proportions are the same as those given in Table 3.1 in Chapter 3.

#### **4.1.2 Fresh Properties**

Table 4.1 shows the unit weights and the slump values of the preliminary mixtures. It can be observed that the unit weight of the mixtures decreases as the percentage of LWA increases. Decreasing the self weight of concrete is a secondary benefit to mixtures that contain LWA. Decreasing dead loads of the concrete can decrease both material and construction costs.

**Table 4.1 Fresh Properties**

	Slump (in.)	Unit Weight (lb/ft <sup>3</sup> )
ControlP	2.75	150.00
Clay1P	2.25	144.80
Clay2P	1.75	141.40
Clay3P	2.00	138.60
Shale3P	1.50	137.40

### 4.1.3 Compressive Strength

Compressive strength values are shown in Table 4.2. All of the cylinders exceeded the specification of AHTD for a 28 day compressive strength of 4000 psi. Each value is the average compressive strength of three cylinders. The Control averaged the highest 28 day and 56 day compressive strengths. As the amount of normal-weight coarse aggregate was replaced with LWA, the compressive strength decreased. Since LWA is intrinsically weaker than the limestone aggregate, its reduced compressive strength weakens the concrete matrix. In a previous study, it was concluded that the use of LWA increased the compressive strength at 90 days by increasing the degree of hydration. This, in turn, counteracted the decrease in aggregate strength by increasing the overall degree of hydration (Espinoza-Hijazin & Lopez, 2011). These results were not the case for our mixtures. The lower strength of the LWA aggregate played a role in decreasing the overall compressive strength of concrete at later ages. It should be noted that the cylinders were submerged in a water bath immediately after demolding at 24 hours of age. Since the cylinders were in an ideal curing environment, the degree of hydration for all mixtures including Control should have been high. The additional water inside the LWA may not have been needed due to these ideal conditions.

**Table 4.2 Compressive Strength**

Mixture	Compressive Strength (psi)			
	1 Day	7 Day	28 Day	56 Day
ControlP	3520	8450*	9070	9570
Clay1P	4990	7850	8770	9320
Clay2P	4280	7150	8250	7970
Clay3P	4210	7530*	7710	8080
Shale3P	4210	6450	7200	6840

\* Indicates specimens tested at 21 days

#### 4.1.4 Moisture Content

As mentioned in Chapter 3, Moisture content of the LWA at the time of batching was assumed. Unlike normal weight aggregate where moisture content can be measured prior to batching, LWA must be assumed and then measured after batching. This is due to the high absorption capacity of LWA and the fact that is submerged in water until batching. All LWA was soaked for 24 hours prior to batching, therefore LWA samples were taken after the 24 hour soaking period (at the time of batching) and tested for actual moisture contents. Table 4.3 compares the actual and assumed moisture contents for the preliminary testing. The assumed moisture contents were based on previous testing.

**Table 4.3 Assumed vs. Actual LWA Moisture Contents**

Mixture	Control	Clay1P	Clay2P	Clay3P	Shale3P
Assumed Moisture Content (percent)	N/A	26.0	26.0	26.0	22.0
Actual Moisture Content (percent)	N/A	**	24.4	26.5	17.4

\*\*Recording Error

It is important to note that the LWA was not in a saturated surface dry (SSD) condition when added to the concrete mixture. While it can be batched in SSD conditions, the method of patting the surfaces of the LWA to that condition can be impractical. In research and in the field, LWA is continually soaked with water and therefore the LWA is saturated when the concrete is batched.

#### 4.1.5 Shrinkage Results

For each mixture, four concrete prisms were cast. Of the four prisms for each mixture, three were selected that yielded the closest values. The first measurements at 24 hours are crucial, because all subsequent test readings are subtracted from that value. That is one reason why four prisms were cast instead of just three. That allowed for all prism shrinkage results to be evaluated and if an outlier existed, it could be disregarded, leaving three prisms to contribute to the shrinkage results. The three prisms with the closest values were chosen. The mean value of these three prisms was calculated and plotted in the figures below. ASTM C157 states that when three specimens are averaged, one standard deviation should be 0.0048 percent or less. All standard deviation values fell within the specifications of ASTM C157 (Table 4.4).

**Table 4.4 Standard Deviation of Preliminary Strain Readings**

Mixtures	Standard Deviation (Percent)							
	Day 1	Day 7	Day 14	Day 21	Day 28	Day 56	Day 90	Day 112
ControlP	0.0000	0.0023	0.0016	0.0015	0.0015	0.0013	0.0016	0.0020
Clay1P	0.0000	0.0003	0.0013	0.0013	0.0018	0.0015	0.0022	0.0013
Clay2P	0.0000	0.0012	0.0016	0.0008	0.0020	0.0015	0.0014	0.0015
Clay3P	0.0000	0.0005	0.0011	0.0007	0.0006	0.0004	0.0008	0.0012
Shale3P	0.0000	0.0003	0.0013	0.0024	0.0010	0.0018	0.0011	0.0023

##### 4.1.5.1 Day 28 Preliminary Strain Results

Figure 4.1 shows the ASTM C157 strain results for the prisms up to 28 days. From day 7 to day 28, the Control mixture experienced higher strain than all the mixtures. At 28 days,

Shale3P showed the lowest amount of strain of the five mixtures tested. The mean strain of Shale3P at 28 days was 218 microstrain, while ControlP's mean strain was 293 microstrain. According to this preliminary research, the presence of soaked LWA decreased strain by up to approximately 26 percent at 28 days. These preliminary tests support the effectiveness of soaked LWA used as an internal curing agent.

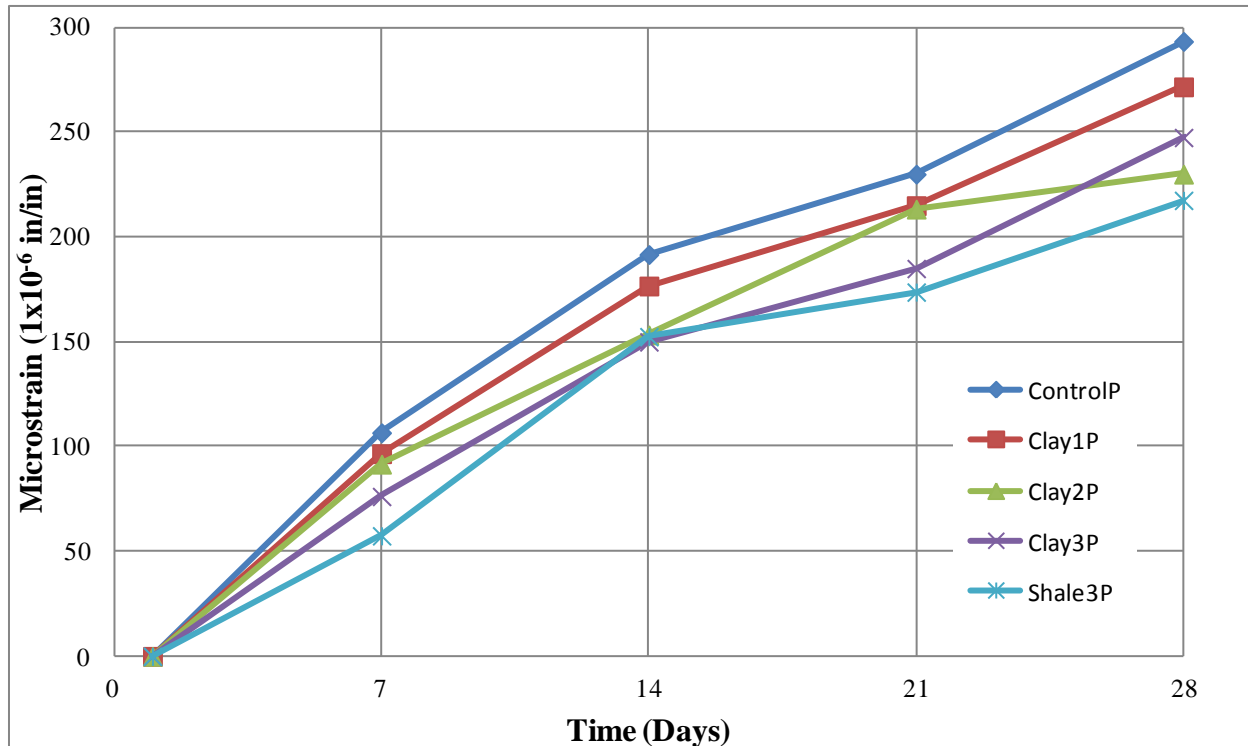
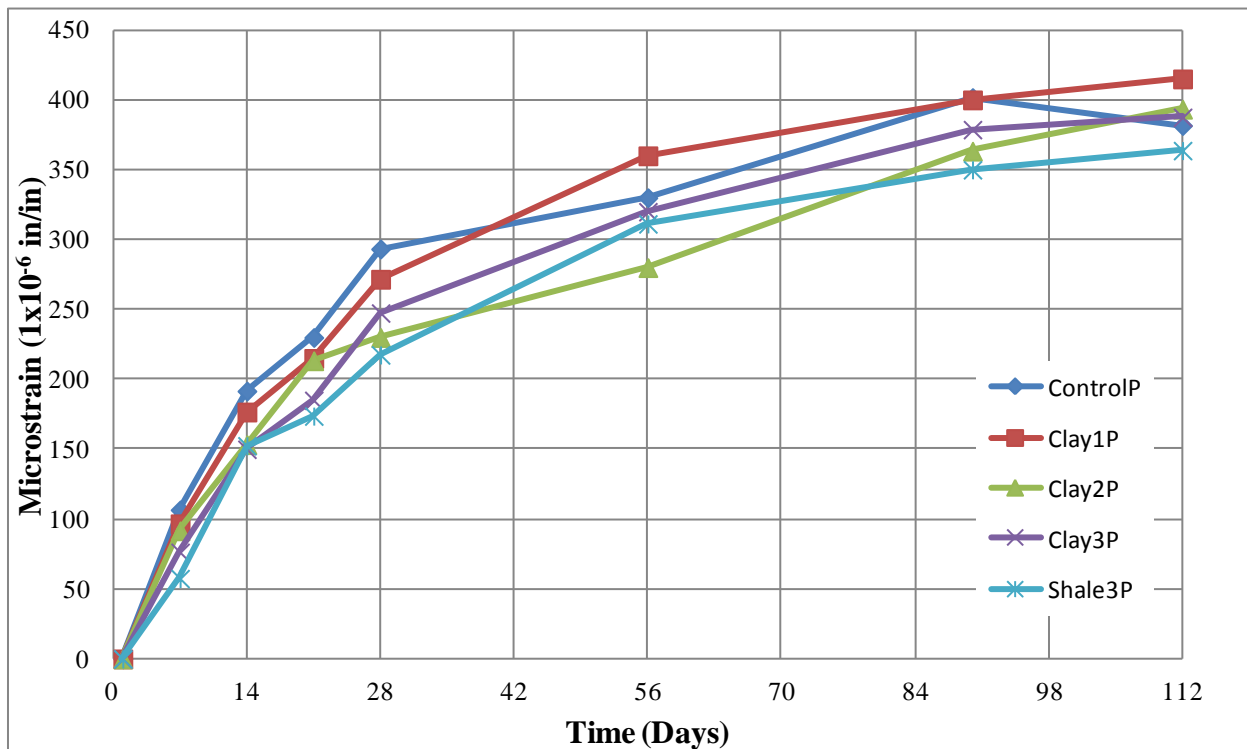


Figure 4.1 ASTM C157 Strain results (28 days)

#### 4.1.5.2 Day 112 Preliminary Strain Results

The preliminary prisms were also tested for shrinkage up to 112 days. The 112 day strain results are given in Figure 4.2. The 112 day data varied from the 28 day results. The strain readings between the Control mixture and the LWA mixtures showed no meaningful differences at 112 days. The Control readings unexpectedly dropped from its 90 day reading and the 112 day reading, while the LWA mixtures continued a slight increase in strain during this period. The differences in strain between the Control and the LWA mixtures at 28 days did not remain

throughout the testing period. This potentially could be attributed to the testing instrument's inaccuracy or that the LWA mixtures did not affect the shrinkage of the concrete prisms. Since implementation of the VWSG was based on the 28 day results of this test, the same mixture proportions that were used in this test were also used in the VWSG testing. As is evident in 112 day results using the VWSG (shown in Section 4.2.5.4), those results were more consistent than the results from ASTM C157.



**Figure 4.2** ASTM C157 Strain results (112 days)

#### 4.2 Phase I: Shrinkage Data using Strain Gages

After monitoring shrinkage using ASTM C157 and finding that LWA did decrease shrinkage in the prisms, VWSG were cast in the prisms to monitor strain and temperature.

#### 4.2.1 Mixture Proportions

Seven different mixtures were tested for 112 days during this phase of research. A control mixture was batched using normal-weight coarse aggregate (Control). For three mixtures a portion of the coarse aggregate was replaced with Expanded Clay LWA by amounts of 100, 200, and 300 lb/yd<sup>3</sup> (Clay1, Clay2, and Clay3, respectively). In the three remaining mixtures, a portion of the coarse aggregate was replaced with Expanded Shale LWA at replacement rates shown above (Shale1, Shale2, and Shale3, respectively). These mixtures will be referred to as (Shale1, Shale2, and Shale3). All mixtures contained 1700 lb/yd<sup>3</sup> of coarse aggregate (normal weight and LWA). The mixture proportions are shown in Table 3.1 in Chapter 3.

#### 4.2.2 Fresh Properties

For each mixture, slump and unit weight were recorded and the results are shown in Table 4.5. As in the fresh properties of the preliminary mixtures, the unit weight decreased as more LWA was replaced with normal weight coarse aggregate. This was expected due to the decreased unit weight of the LWA in comparison with the portion of normal weight coarse aggregate that it replaced. The slump results were more variable than desired. Sealing the prism molds for the first 24 hours was important due to the difference in slump. By sealing the prisms, surface evaporation, which would have been increased for the mixtures with higher slump results, was eliminated. Sealing the prisms reduced the variability between the mixtures caused by differences in slump.



**Table 4.5 Fresh Properties**

Mixture	Slump (in)	Unit Weight (lb/ft <sup>3</sup> )
Control	1.50	148.70
Clay1	8.00	144.20
Clay2	5.00	142.50
Clay3	2.25	139.30
Shale1	4.00	146.10
Shale2	4.25	143.40
Shale3	6.50	139.50

### 4.2.3 Compressive Strength

Twelve 4x8 inch cylinders were cast for each mixture. Each value shown in Table 4.6 is the average of three cylinders. All mixtures exceeded the AHTD specified 28 day strength of 4000 psi by 7 days of age. Thus, while the compressive strengths decreased as the amount of LWA was added, all strengths were well above the specification. The presence of the water stored in the LWA did not increase the compressive strength in excess of the Control in any of the LWA mixtures. As mentioned in Section 4.1.3, some studies have shown that internally cured mixtures can increase the compressive strength over the control mixture, but this was not the case for this study. It is possible that the LWA mixtures could continue to gain strength at a greater rate in later ages than the Control mixture, but no compressive strength testing was performed after 56 days.

**Table 4.6 Compressive Strength**

Mixture	Compressive Strength (psi)			
	1 Day	7 Day	28 Day	56 Day
Control	3850	6430	8460	8880
Clay1	3260	6060	7440	8050
Clay2	3610	6090	7200	7960
Clay3	3940	6320	7100	7790
Shale1	4030	6450	7600	8080
Shale2	3820	6290	7470	8110
Shale3	3580	5770	7090	7460

#### 4.2.4 Moisture Content

Similar to Section 4.1.4 the moisture content of the LWA had to be assumed due to the fact that all LWA was soaked for 24 hours prior to batching. Even after testing multiple preliminary moisture contents of the LWA's, the moisture contents varied between the mixtures. While the moisture contents did vary, it is not likely that the difference between the estimated and the actual values significantly impact the shrinkage of concrete. The largest difference between the assumed moisture content and the actual moisture content of the LWA was in the Clay3 mixture, which was an increase of 7.3 percent. This difference in assumed and actual moisture content of the LWA increased the w/cm from 0.44 to 0.474.

**Table 4.7 Assumed vs. Actual LWA Moisture Contents**

Mixture	Clay1	Clay2	Clay3	Shale1	Shale2	Shale3
Assumed Moisture Content (percent)	26.0	26.0	26.0	22.0	22.0	22.0
Actual Moisture Content (percent)	28.2	26.4	33.3	19.5	23.8	17.6

#### 4.2.5 Shrinkage Results

Three prisms, each with one, embedded VWSG, were used to record strain data for each mixture. The strain results from the three prisms were averaged together and that mean value for each mixture is what is shown in the following sections. This was done so that the results could be compared with the ASTM C157 results, which also took the mean value of three prism results. Using the VWSG yielded values between the three prisms for each mixture with low standard deviations. The standard deviations fell within the range (less than 0.0048 percent

standard deviation) prescribed in ASTM C157. Table 4.8 shows the standard deviation results using the VWSG.

**Table 4.8 Standard Deviations of VW Strain Gage Results**

Mixtures	Standard Deviation (Percent)					
	Day 1	Day 7	Day 28	Day 56	Day 90	Day 112
Control	0.00022	0.00049	0.00096	0.00115	0.00122	0.00106
Clay1	0.00019	0.00026	0.00058	0.00087	0.00109	0.00100
Clay2	0.00043	0.00060	0.00028	0.00022	0.00051	0.00060
Clay3	0.00057	0.00035	0.00030	0.00043	0.00073	0.00098
Shale1	0.00018	0.00026	0.00047	0.00039	0.00060	0.00077
Shale2	0.00009	0.00034	0.00075	0.00113	0.00165	0.00173
Shale3	0.00041	0.00013	0.00045	0.00052	0.00088	0.00110

When reviewing the strain results in the following figures, note that any horizontal line in the data represents a time period where the power was lost. Several such occasions occurred during the months that the data were being recorded.

#### 4.2.5.1 Day 1 Strain Results

A major advantage in measuring strain using VWSG is that strain and temperature readings can be recorded immediately after casting the concrete into the molds. ASTM C157 is limited due to the fact that strain readings for the entire testing period are based off of the 24 hour length measurement. Therefore, there is no information available about strains that occur within the first 24 hours. Evaluating the effects of internal curing during the first 24 hours may provide important information on its overall influence of shrinkage even at later ages. One of the objectives of the research project was to determine whether internally cured conventional concrete showed a difference in strain readings at ages less than 24 hours when compared to the Control mixture. Since the concrete mixtures in this research were not HPC, that is, they had a relatively high w/cm of 0.44, the question was examined, “would the concrete matrix benefit from the internally stored water in the LWA or would there be enough water in the paste matrix

to not draw out the water from the LWA pore structure within the first 24 hours?” Answering this question would provide further insight on whether conventional concrete truly benefits from internal curing.

It is important to note that during the first 24 hours the specimens were sealed so not to lose moisture to the environment. This step was taken to reduce the number of variables that could influence the results. Since slump values for the different mixtures varied, the surrounding environment could affect the mixtures differently. If one mixture contained a higher slump, it could be more susceptible to surface evaporate due to a higher amount of bleed water. Effort was taken to seal the specimens immediately after the surfaces were finished so that the results of the various mixtures that could be experimentally compared with confidence.

Figure 4.3 shows the strain values of the clay LWA mixtures compared to the Control during the first 24 hours. When viewing this and all other graphs plotting strain, it is important to note that negative strain values correspond to an elongation of the strain gages. This elongation can be due, in part, to expansion of the concrete mixture. At very early ages, prior to 4 hours, all three clay mixtures show greater expansion than the Control mixture. This is likely due to the presence of water in the LWA that is readily available to aid in the hydration process. The presence of the soaked LWA in the mixtures affected the degree of expansion that occurred. For the first 20 hours, the difference did not exceed 30 microstrain. The surfaces of the steel molds were oiled to decrease the bond between the concrete and the steel. However, adhesion did occur during the first 24 hours which could also have affected the amount of negative strain in all of the prisms. The bond between the concrete and steel molds provided some degree of restraint to the concrete shrinkage within the first 42 hours. This could induce tensile stresses in the prisms which could explain a portion of the negative strain shown during the first 24 hours. There was

still a difference in the extent of negative strain between the LWA mixtures and the Control which is attributed to the additional water provided by the LWA. In future testing, using plastic sheeting to line the inner surfaces of the steel molds would be advantageous in reducing the external restraint while the prisms are in the molds.

Figure 4.4 shows the strain values of the shale LWA mixtures compared to the Control during the first 24 hours. The shale LWA mixtures did not vary from the Control to the same degree as the clay LWA mixtures. The higher amount of shrinkage that occurred in the shale mixtures is attributed to the lower moisture content when compared with the clay LWA. During the first four hours, the shale mixtures did not show a difference in strain as did the clay mixtures. However, as the Control mixture began to shrink at around four hours, the shale mixtures continued to expand. For mixtures containing clay or shale LWA, there was noticeable difference in volume change during the first 24 hours after casting.

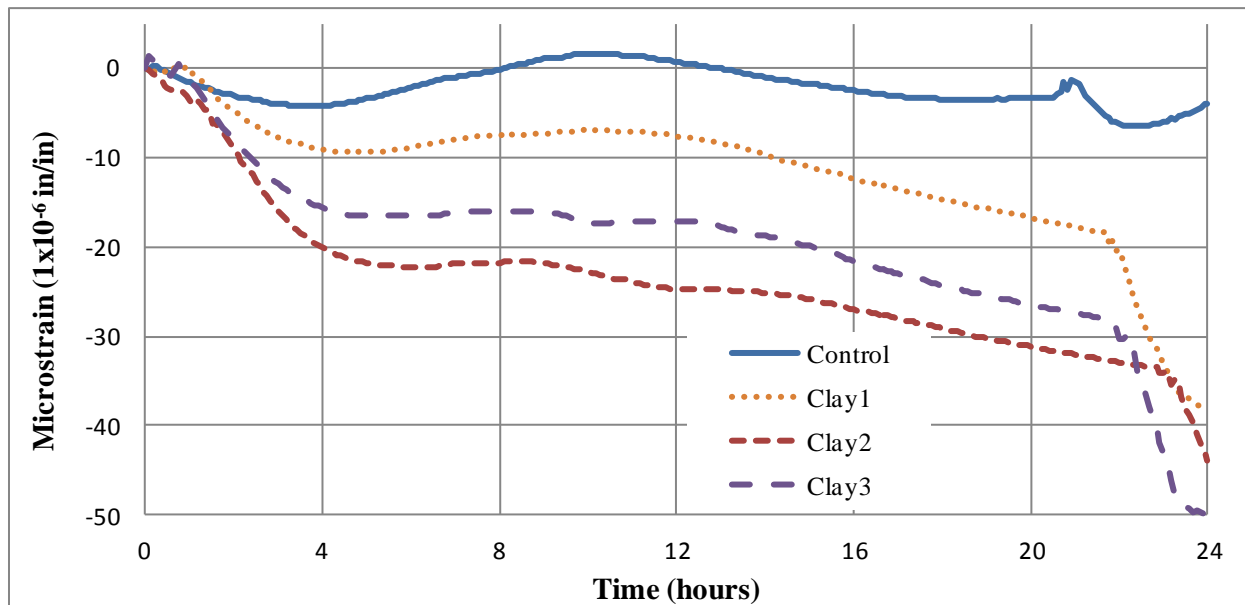
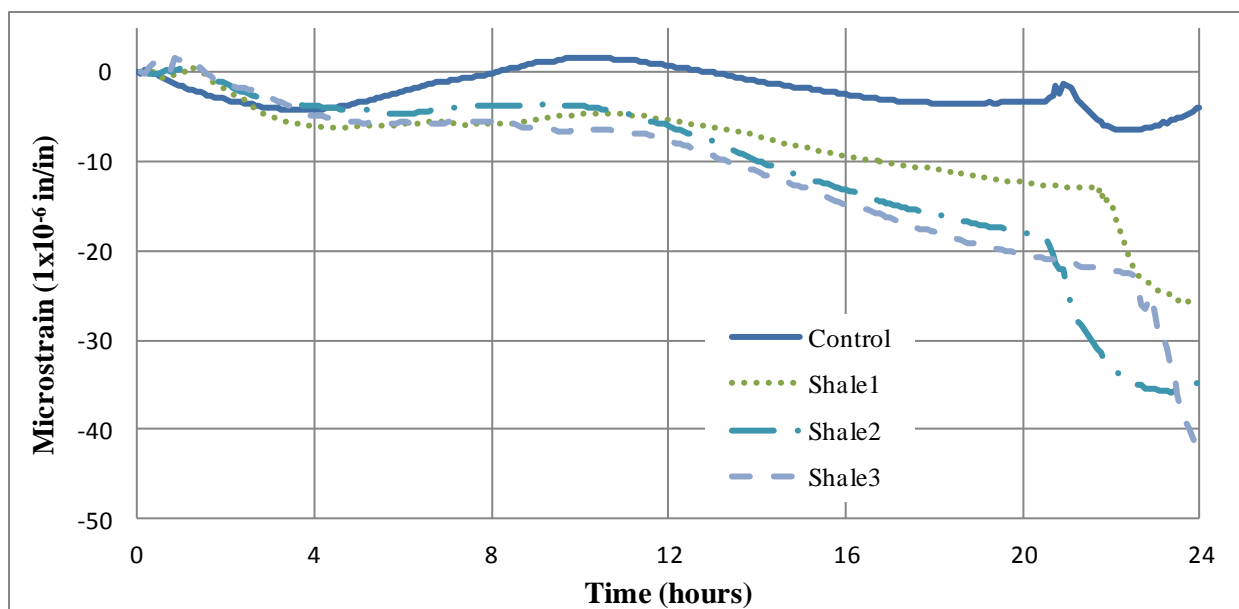


Figure 4.3 Expanded Clay Strain (24 hours)



**Figure 4.4 Expanded Shale Strain (24 hours)**

Twenty four hours after casting, the cellophane wrap was removed and the concrete prisms were demolded. While the inner surfaces of the steel molds were oiled prior to casting, the process of removing the hardened concrete prisms from the molds proved difficult. Since each of the prisms had an embedded VWSG, care was taken while demolding in order not to affect the readings. However, as shown in Figures 4.3 and 4.4, a sudden reduction in strain is evident at 24 hours when the prisms were demolded.

All prisms were demolded in the same way to maintain consistency. Various methods to demold the prisms with minimal impact should be investigated further to limit disruption of the strain results. A possible solution would be to line the molds with thin polyethylene sheeting so that the concrete and steel would not adhere to each other. In all of the prisms, the strain readings resumed a normal trend after the demolding process.

#### 4.2.5.2 Day 7 Strain Results

The 7 day results show how all of the VWSG readings resumed a normal trend after the drop in strain due to the demolding process. Figure 4.5 shows the clay LWA mixtures in comparison to the Control mixture. At 7 days, the reduction in shrinkage strain is evident as the amount of LWA replacement is increased.

Figure 4.6 shows the strain in the shale LWA mixtures and the Control up to 7 days. Similar to the 24 hour results, the shale mixtures do not vary as much from the Control as do the clay mixtures. This is attributed to the lower moisture content in the shale LWA mixtures. Although the reduction is not as great as the clay mixtures, the shrinkage strain decreases as the content of shale LWA increases. The shale mixtures also do not vary as much as the clay mixtures in relation to each other.

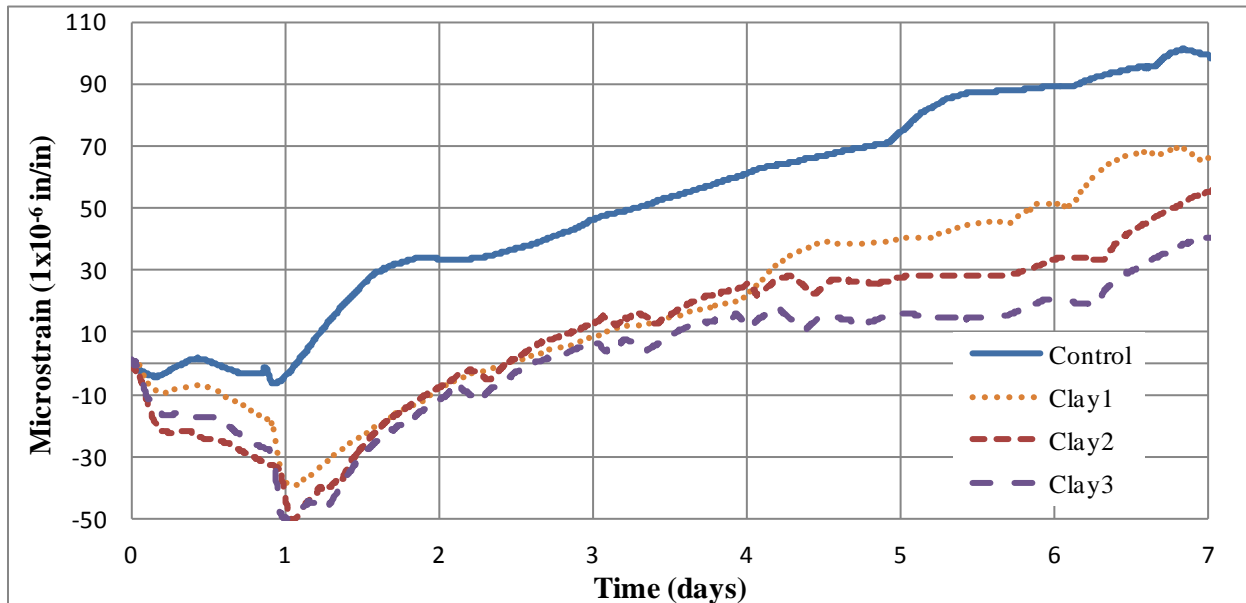
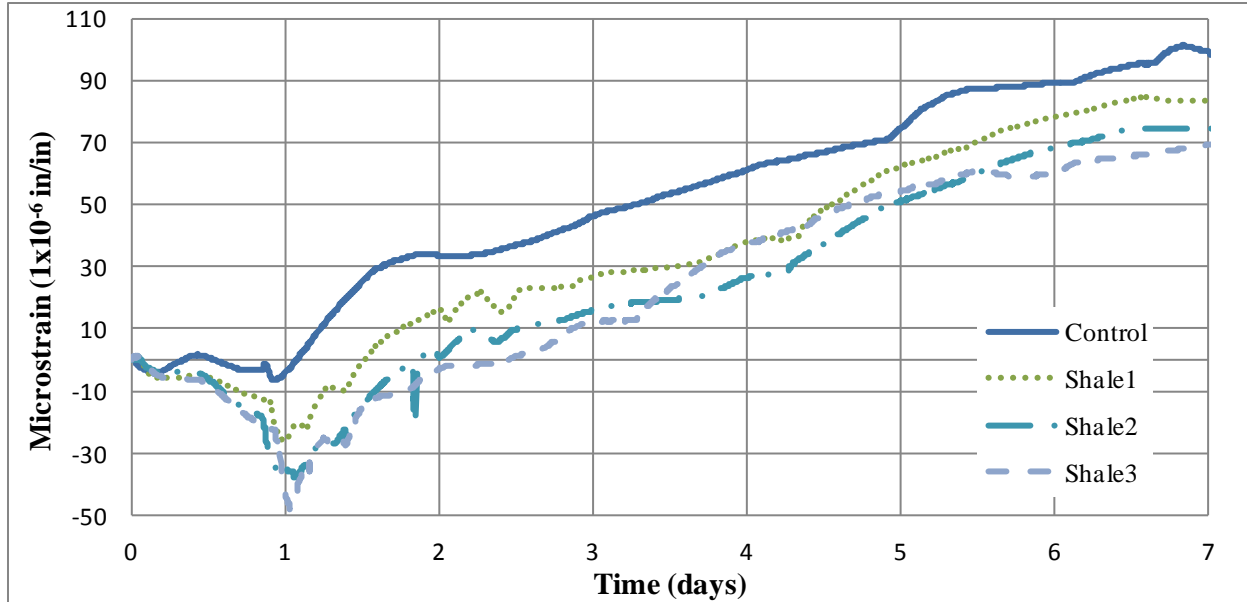


Figure 4.5 Expanded Clay Strain (7 days)



**Figure 4.6 Expanded Shale Strain (7 days)**

#### 4.2.5.3 Day 28 Strain Results

Strain data for the first 28 days are illustrated in Figure 4.7 (Expanded Clay Mixtures) and Figure 4.8 (Expanded Shale Mixtures). Figure 4.7 shows a notable difference in strain between the Control Mixture and the mixtures containing the Expanding Clay. As the coarse aggregate was replaced by LWA, the strain decreased. While the difference in strain between Clay1 and Clay2 is negligible, there is a measurable difference between the Control and Clay3 at 28 days. From Figure 4.8 the data show less of a difference in strain between the Shale mixtures and the control than is the case for the Clay. These results are reasonable when considering the lower absorption capacity of the Shale (12.9 percent) than in relation to Clay (15 percent). Shale1 and Shale2 mixtures show no measurable difference from one another as well as no measurable difference with Control at 28 days. However, the lack of separation of the Control with Shale1 and Shale2 at 28 days is, in part, due to a period of 2 days where data was lost for the Control. The time of the time data is revealed by the horizontal lines in both Figures.



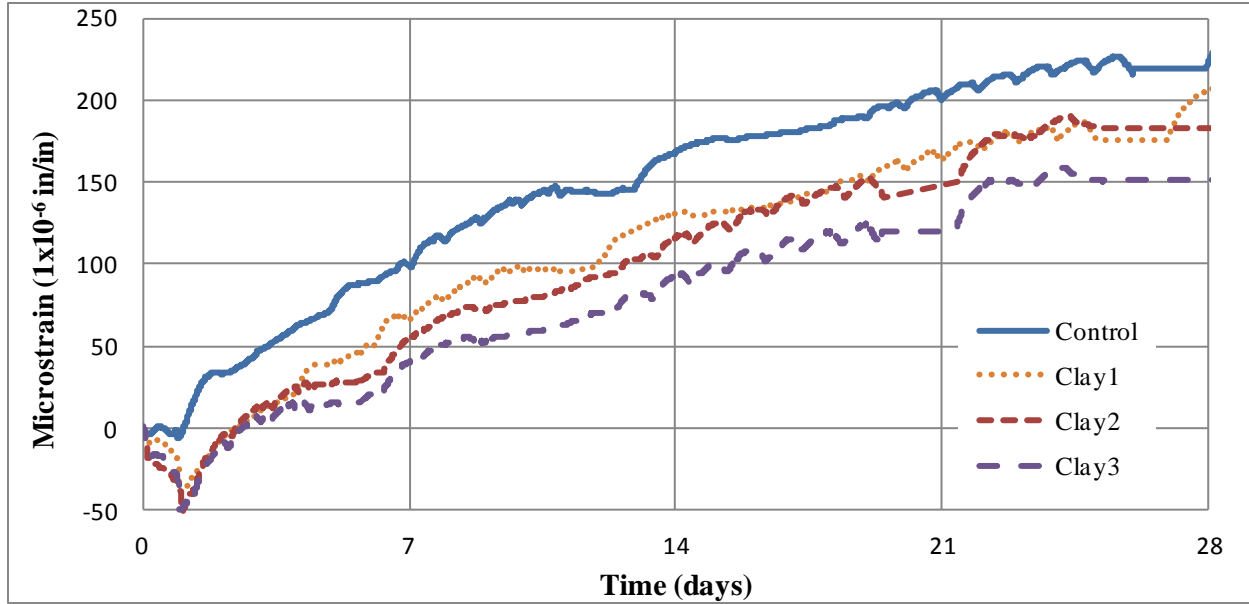


Figure 4.7 Expanded Clay Strain (28 days)

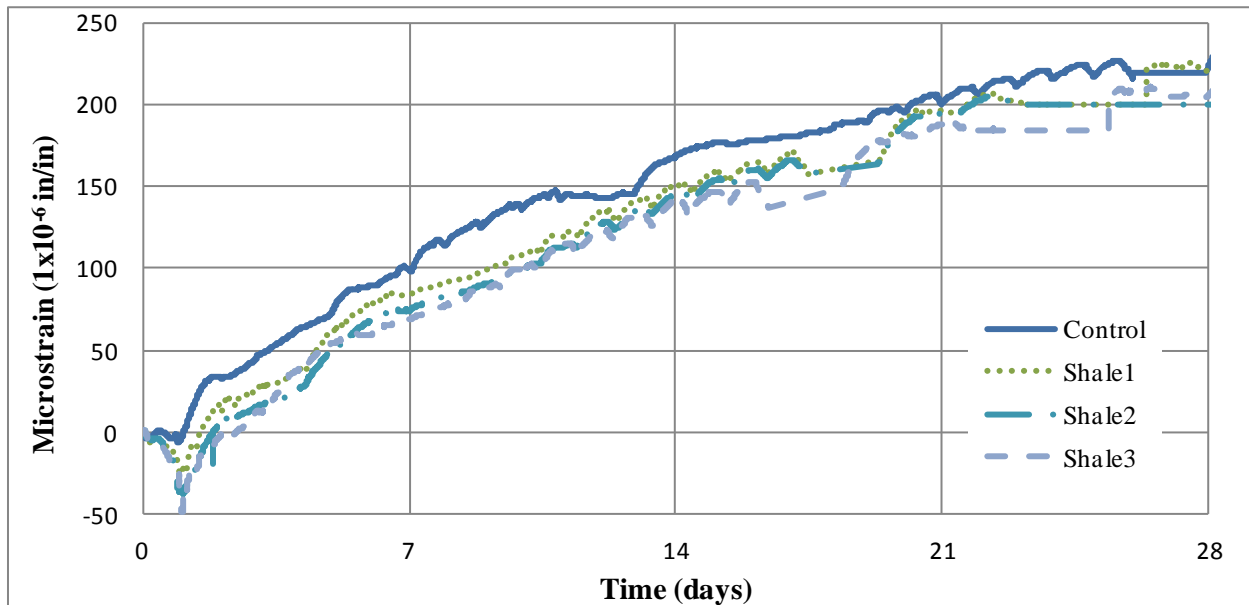


Figure 4.8 Expanded Shale Strain (28 days)

#### 4.2.5.4 Day 112 Strain Results

Strain data for the entire 112 day testing period are shown in Figures 4.9 (Expanded Clay Mixtures) and 4.10 (Expanded Shale Mixtures). For the clay mixtures, the decrease in strain

between the Control and Clay3 continues for up to 112 days. Clay1 and Clay2 mixtures show no difference in strain in relation to each other at 112 days, but were lower than the Control. It was initially hypothesized that at these later ages, the Control mixture would continue to shrink while the clay and shale LWA mixtures would experience a decrease in shrinkage. This was not the case in this testing program. The Control as well as the clay and shale LWA mixtures experienced a similar rate of shrinkage at later ages. The difference in strain between the Control and the LWA mixtures occurred at early ages and was maintained, to a degree, throughout the remainder of the testing period.

The Expanded Shale mixtures showed no significant decrease in shrinkage at 112 days when compared to the Control. While there is a difference in strain in Shale3 and Control, the difference is small, approximately 20 microstrain. Throughout the entirety of the testing period, the Expanded Shale mixtures had less of an effect on strain than the Expanded Clay mixtures.

It is also evident from Figures 4.9 and 4.10 that all mixtures experienced a reduction in strain at approximately 84 days (varies depending on the date the mixture was cast). This decrease in strain was due to a change in temperature in the environmental chamber. Concrete expands when temperature increases and contracts when temperature decreases (Nilson, Darwin, & Dolan, 2010). This change decreased the strain for all test specimens. Therefore, the drop in strain readings is temperature-related artifact, and the specimens would not have experienced a drop in strain from around 84 days to 112 days if it were not for the temperature decrease. The cause of the temperature fluctuations are highlighted in section 4.2.6.

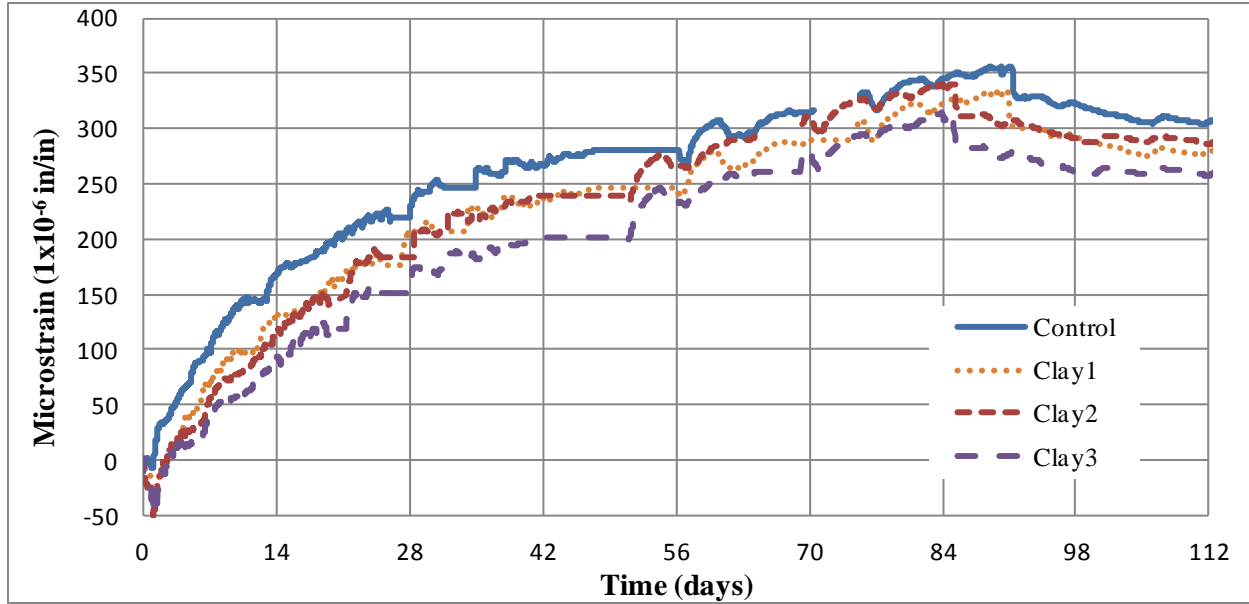


Figure 4.9 Expanded Clay Strain (112 days)

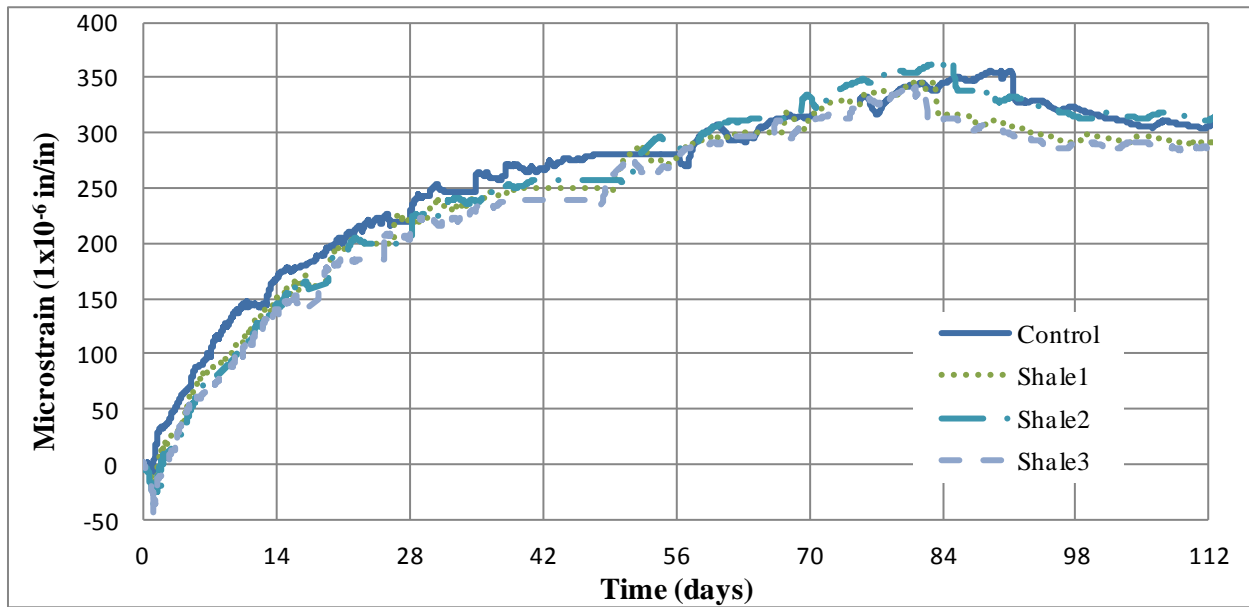
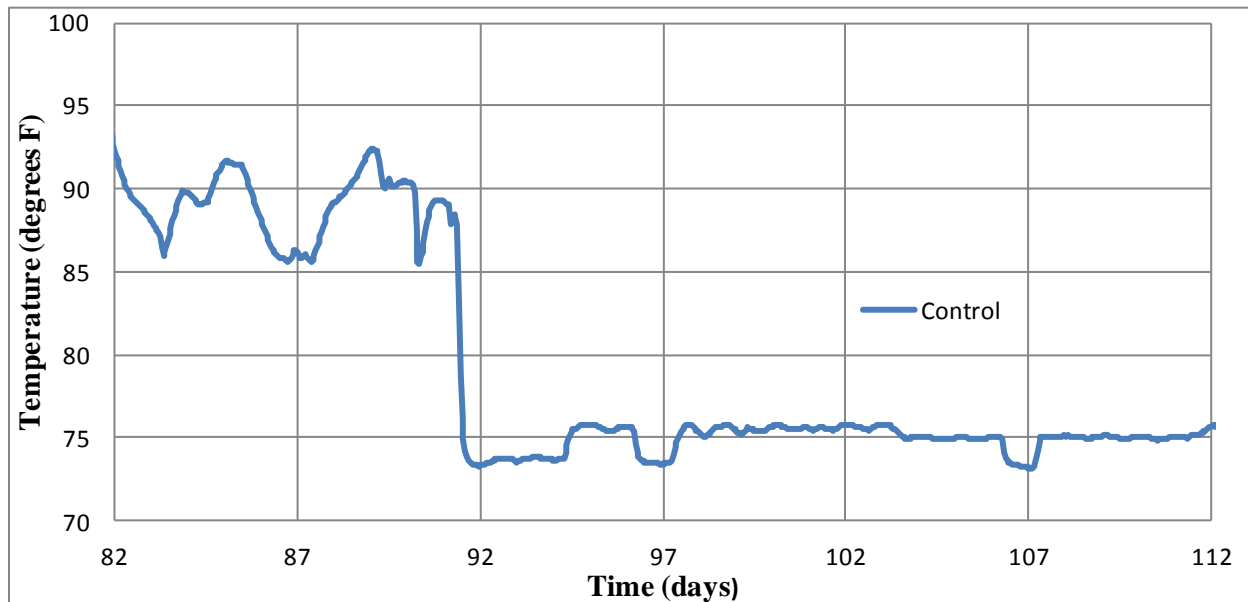


Figure 4.10 Expanded Shale Strain (112 days)

#### 4.2.6 Temperature Results

In the Figures above, the Control, Expanded Clay, and Expanded Shale mixtures experienced local fluctuations in strain throughout the testing period. These small peaks and

troughs are due to temperature variations in the environmental chamber. During the testing period, power to the environmental chamber failed on multiple occasions. For a significant portion of the testing period, the cause of the power failure was unknown. The cause for the power outages was subsequently determined to be a clogged air filter in the air conditioning unit. The temperature variations were not planned, nor ideal for testing concrete strain, but all of the prisms were exposed to the same environmental conditions through the entire testing period. Also, all mixtures were cast within 10 days of each other, so the temperature variation occurred at similar ages for all specimens. The effects of temperature can be observed in Figures 4.7 and 4.8 (day 28 strain). The reduction in temperature resulted in a decrease in strain. See Figure 4.11 for illustration of temperature drop of the Control mixture. Each VWSG contained a thermistor (Figure 3.9) that recorded concrete temperature. As shown Figure 4.11, the control mixture experienced a temperature drop of approximately 15 degrees F at 91 days of age. All specimens experience the same decrease in temperature, but only the Control mixture is shown.



**Figure 4.11 Temperature Decrease of Control Mixture**

#### 4.2.7 Data Comparison between ASTM C157 and Strain Gage Results

Strain results for both ASTM C157 and VWSG methods are discussed previously in Sections 4.1 and 4.2, respectively. In almost all cases, the strain values recorded using ASTM C157 methods were higher than the strain values recorded with the VWSG. Table 4.9 lists the strain reading values for ASTM C157 and VWSG.

**Table 4.9 Comparative Strain Readings**

Mixture	Test Method	Results (microstrain)			
		7 Day	28 Day	56 Day	112 Day
Control	ASTM C157	107	293	330	382
	Strain Gages	99	223	*	306
Clay1	ASTM C157	97	272	360	415
	Strain Gages	66	208	241	279
Clay2	ASTM C157	92	230	280	393
	Strain Gages	55	*	264	287
Clay3	ASTM C157	76	248	320	388
	Strain Gages	40	151	232	258
Shale3	ASTM C157	58	218	311	364
	Strain Gages	69	206	279	286

\* Error in Data Recording

In all of the tests using VWSG, the demolding process caused a sudden decrease in strain. This decrease could be a factor that caused the VWSG readings to consistently produce lower strain values compared with ASTM C157 method. Also, at 24 hours most of the VWSG produced a negative strain reading. Since ASTM C157 starts readings at 24 hours (strain equal to zero at this point), then this could also be a factor in the difference in strain values. Even with these contributing factors, the ASTM C157 results had a greater rate of change throughout the testing period than the VWSG results. The VWSG were placed in the prisms used in accordance with ASTM C157 to compare the strain readings between the two different testing methods. For each prism, a VWSG was placed in the center of the mold. A six-inch VWSG measured the

change in length of its end blocks. ASTM methods measure the change in length from the gage studs cast into each end of the prism. Theoretically, this difference in the distance between measuring points should not change the strain reading since the change in length is divided by the original length, but the location and size of the VWSG may contribute to the lower strain readings throughout the course of the testing period.

### **4.3 Phase II: Plastic Shrinkage Testing**

#### **4.3.1 Mixtures**

As discussed in the Literature Review, difficulties arise when trying to test and quantify plastic shrinkage cracking in concrete. Concretes with high coarse aggregate contents pose challenges in evaluating shrinkage, because the aggregate in the mixture acts as internal restraint against all types of shrinkage, including plastic shrinkage. In an effort to effectively test and measure plastic shrinkage cracking in concrete, 16 separate mixtures were tested during this phase of the research project. The major problems faced while trying to develop plastic shrinkage cracks in test slabs were: inadequate external restraint, high internal restraint due to aggregate, and workability and the resulting finish of the mixtures. The different mixtures will be discussed further in the following sections explaining the various test methods that were attempted.

For the plastic shrinkage testing, the selection of which mixtures to test was based on the results from the Phase I, the drying shrinkage testing. To obtain a baseline, the Control batch had to produce plastic shrinkage cracks. If the Control slabs did not produce plastic cracking, then it would not be expected for the mixtures containing LWA to crack either. Initiating plastic shrinkage cracking in the Control slabs proved to be difficult. However, once the mixture proportions and formwork could produce consistent cracking, then the LWA mixtures could be

evaluated and compared to the Control. Instead of testing all the different replacement rates of LWA, just the LWA mixture that produced the best results from phase I, which was Clay3, was tested and compared with the Control mixture.

#### **4.3.2 Developing Test Slabs**

At the beginning of this phase of the research, the test methods first developed by Kraai in 1985 were followed. Kraai cast a 2 x 3 ft. slab that was  $\frac{3}{4}$  inch thick, and nailed wire mesh to the bottom of the formwork around the perimeter. The wire mesh was then bent up 90 degrees (Kraai, 1985). This provided external restraint that increased the tensile stresses in the concrete as shrinkage occurred. This increase in stresses would cause surface cracks in the concrete slabs if the stresses exceeded the concrete tensile capacity. In addition, Kraai removed the coarse aggregate by wet sieving the concrete immediately after mixing. By using cement paste instead of concrete, shrinkage would increase, causing more cracks. However, for this research project, the objective of both Phase I and Phase II was to evaluate the effects of internal curing using coarse LWA. This eliminated the option of wet sieving the concrete. If the coarse aggregate was removed from the control mixture, then adding coarse LWA in the other mixtures would decrease the shrinkage of the slab by the presence of the aggregate, itself. These mixtures would not be comparable, in that case.

Another issue in implementing the Kraai's test methods was the slab thickness. Since AHTD coarse aggregate gradations specify a maximum size aggregate of  $1\frac{1}{4}$  inch, the slab thickness of  $\frac{3}{4}$  inch would not be adequate for the mixture designs used in this study. Therefore, the thickness of the slab was increased to  $1\frac{3}{8}$  inch.

Testing began using 4 x 4 ft. slabs with a thickness of  $1\frac{3}{8}$  inch. Two and one-half inch wide strips of  $\frac{1}{2}$  inch square wire mesh was stapled around the perimeter of the formwork and

the bent up at approximately 90 degrees. These first test slabs produced no surface cracks (Figure 4.12). In order to promote transverse cracking and increase the surface area of the slabs, the longitudinal direction of the slabs was increased to 8 ft., which made the slabs 4 x 8 ft. Test slabs with the new dimensions were cast, but there were still no surface cracks developing.



**Figure 4.12 4' x 4' Test Slab**

At this point, it appeared that the concrete mixture was not experiencing enough shrinkage to produce cracks at the surface. So, the research team decided to move to testing plastic shrinkage cracking using ASTM C1579 *Standard Test Method for Evaluating Plastic Shrinkage Cracking of Restrained Fiber Reinforced Concrete (Using Steel Form Insert)*, which is explained in Section 2.6.1.3 of Chapter 2. While this test method is for testing the effects of steel fibers cast in concrete, it was thought that it could be related to testing the effects of internal curing on plastic shrinkage as was done by Henkensiefken et al. (Henkensiefken, Briatka, Bentz, Nantung, & Weiss, 2010). The steel insert was fabricated and the formwork was built per the specifications. The difference in our preliminary tests and the ASTM C1579 specifications was



the environmental conditions. These tests were conducted outdoors in July. As mentioned above, the environmental conditions at this time produced drying evaporation rates that were well above the 0.2 lb/ft<sup>2</sup>/hr prescribed by ACI 305 for dry conditions. Preliminary tests were administered using the Control mixture cast in two molds. Once again, plastic shrinkage cracks were not observed in the slabs. In order to increase shrinkage, the initial amount of 1700 lb/yd<sup>3</sup> of coarse aggregate was then reduced to 1500, then to 1300, and finally to 850 lb/yd<sup>3</sup>. Surface cracks did not appear on any of the preliminary slabs using ASTM C1579. This test method proved ineffective in producing plastic shrinkage cracking in the Control mixture, so this test was not used in examining the effect that coarse LWA has on plastic shrinkage cracking. The research went back to evaluating thin slabs and trying to determine how to produce plastic shrinkage cracks in tests slabs cast with concrete.

Literature by Weiss et al. analyzed shrinkage cracking using more rigid formwork (Weiss, Yang, & Shah, 1998). They cast concrete into a small 100 x 75 mm steel mold with threaded rods at the ends to provide restraint. The threaded rods were used so that the fresh concrete could be cast around the rods and obtain a strong bond to the threaded surface. Once the concrete contracted, the bond with the rods would increase tensile stresses, resulting in cracking. While this test method did not specifically test plastic shrinkage, it did highlight the need for adequate restraint to produce cracks in concrete. Pelisser et al. analyzed plastic shrinkage cracking in thin slabs cast with cement mortar in a similar fashion to Kraai's work. One difference in the testing was that Pelisser used steel angle instead of wire mesh for external restraint (Pelisser, da S. Santos Neto, La Rovere, & de Andrade Pinto, 2010). Pelisser's reasoning for using steel angle instead of wire mesh was not stated, but the increased rigidity of the steel angles when compared to the wire mesh would increase the overall restraint of the

formwork. It is important to note that Pelisser did not test concrete, but only tested cement mortar. He noted that the influence of coarse aggregate would reduce the amount of shrinkage that would take place and, therefore, omitted aggregate from his mixtures. From the examples of these two studies, it was concluded that the wire mesh used in this research program did not provide enough restraint to cause cracking at the slab's surface. Since the goal was to measure plastic shrinkage, casting a small specimen similar to Weiss et al. would be insufficient due to a small surface area. So 4 x 8 ft. thin slabs were used as before, but  $\frac{3}{4} \times \frac{3}{4} \times \frac{1}{8}$  inch steel angle members were fixed around the entire perimeter instead of wire mesh (Figure 3.11 in Chapter 3). At this point, it was still unknown if the slabs would crack, because of the high internal rigidity of the Control mixture and the increased thickness of the slab compared to previous literature.

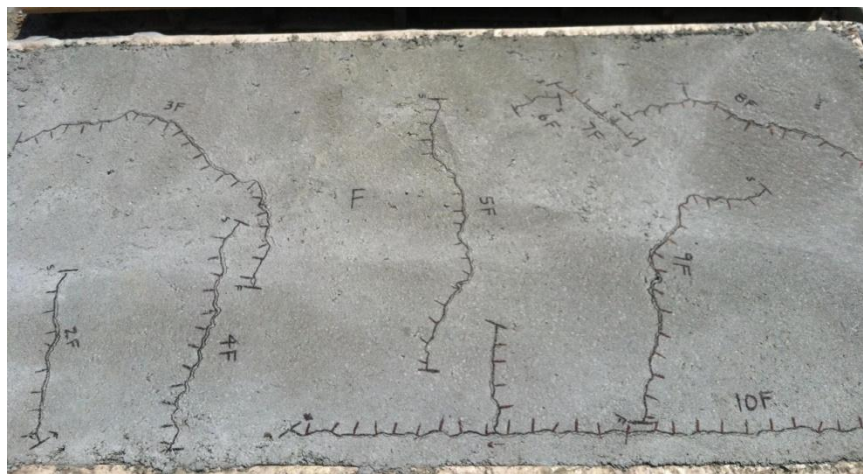
The first test slabs using the steel angle were evaluated. Two slabs were cast at the same time. The concrete mixture had a slump of less than an inch. When the slabs were cast, the concrete mixture was too dry and a smooth surface finish was not obtained. Both test slabs did not experience any plastic shrinkage cracking. This test proved how slump affects plastic shrinkage cracking. Our findings agree with the conclusion by Qi et al. that concretes with low slump are less susceptible to plastic shrinkage cracking due to a decrease in settlement (Qi, Weiss, & Olek, 2003). This relationship between slump and plastic shrinkage is very important when trying to quantify plastic shrinkage cracks. Slump values of different concrete mixtures should be very similar so that comparisons of the amount of cracking can be compared. This is one of multiple factors that make analyzing and quantifying plastic shrinkage cracking difficult.

The Control mixture was batched again and this time the amount of superplasticizer was increased so that slump was four inches. The concrete was cast from the same mixer for two slabs. These were the first slabs that developed plastic shrinkage cracks. Plastic shrinkage

cracking became visible approximately 20 minutes after finishing the slab surfaces. The use of the steel angle members was very effective in increasing the tensile stresses in the concrete leading to cracks. Figure 4.12 shows a test slab approximately one hour after casting. Figure 4.13 shows a test slab 24 hours after casting and after the cracks were mapped and measured. The same Control mixture was batched again and cast into two 4 x 8 ft. slabs.



**Figure 4.13 Slab After Formation of Plastic Shrinkage Cracks**



**Figure 4.14 Slab Cracks Mapped 24 Hours After Casting**

Since the Control slabs were cast, producing plastic surface cracks, the next step was testing the Clay3 mixture. The same mixture proportions used in Phase I for Clay3 were batched

and cast onto two 4x8 ft slabs. The high volume of coarse aggregate in this mixture caused the surface of the slabs to be unworkable. There was not enough paste in the mixture to produce a smooth finish. After this test, various other test mixtures were batched to improve the surface finish of the slabs.

To increase the surface finish and still maintain the same amount of LWA that was used in the previous testing, the amount of normal weight coarse aggregate decreased. The proportions of the Clay3 mixture were modified to increase the workability and surface finish. Clay3U, which denotes the updated Clay3 mixture, was cast onto two 4x8 ft. slabs and cracking was observed and measured. Since the LWA clay mixture had been modified to increase workability, then a modified mixture had to be cast and tested for the Control, as well. The ControlU, which denotes the updated Control mixture, was cast onto two 4x8 ft. slabs and cracking was observed and measured. The mixture proportions are shown in Table 4.10.

**Table 4.10 Mixture Proportions for Test Slabs**

Mixture	Unit Weight per Unit Volume (lb/yd <sup>3</sup> )					
	Cement	Coarse Aggregate	LWA	Sand	Water	w/c
Control	611	1700	0	1440	269	0.44
ControlU	611	1357	0	1773	269	0.44
Clay3	611	1400	300	1107	269	0.44
Clay3U	611	1057	300	1440	269	0.44

The ControlU and the Clay3U mixtures were evaluated in the following section for plastic shrinkage cracking. Due the scope of this phase of the research project and the timeline, no further testing of thin slabs was performed after successful Control and Clay mixtures were cast and evaluated. This phase of research was, in many ways, preliminary to future testing of the effects of internal curing on plastic shrinkage cracking.

### 4.3.3 Slump

Slump plays a significant role in the amount of plastic shrinkage that takes place. The lower the slump, the less susceptible the concrete mixture can be to plastic shrinkage. The role that slump plays on the extent of plastic shrinkage cracking that occurs was verified through the research program. In the preliminary testing, it was concluded that if the slump for a particular mixture was low, then the amount of surface cracks would decrease. For this reason, the researchers attempted to obtain similar slump values for the different mixtures. For the ControlU mixture, a slump of 3.5 inches was obtained. For the Clay3U mixture, a slump of 5.5 inches was obtained. Since the Clay3U mixture's slump was higher than the ControlU mixture, then it can be assumed that the difference in slump between the two mixtures did not aid the Clay3U mixture in yielding less cracks, rather, the higher slump of Clay3U mixture could possibly cause the cracking results to be conservative.

For each mixture, two slabs were cast so that the cracking results could be compared between the two to evaluate the consistency of the amount of cracking. In all cases except ControlU, the first slab that was placed yielded more cracks than the second slab. These results were attributed to a decrease in flowability or slump (which can be time dependent). The concrete for the second slab remained in the rotating mixer while the concrete was being placed in the first slab. While efforts were taken to decrease the time between casting the first and the second slab, the increased time from batching to placement of the second slab still affected cracking. Therefore, for each batch, the timing and procedures were done in a consistent manner throughout the testing period to mitigate the variables that affect plastic cracking results.

#### 4.3.4 Environmental Conditions

As mentioned in Ch. 3, all plastic shrinkage testing was performed outdoors. The size of the slabs made it impractical to cast and evaluate the slabs indoors. Due to this phase of the research taking place in the summer months (June-August), the research team took advantage of the natural environmental conditions that promote drying conditions. All slabs were cast at 90 degrees F or higher. All slabs were cast on days with direct sunlight to further the extent of drying on the slab surfaces. Finally, a large fan was used to create a constant wind velocity for four hours after the slabs were finished. The combination of temperature, wind velocity, and low humidity levels all contributed to the drying conditions needed to promote plastic shrinkage cracking. The drying conditions were measured by the evaporation rate for the first four hours after finishing. ACI 305 *Hot Weather Concreting* suggests that a minimum rate of evaporation of at least 0.2 lb/ft<sup>2</sup>/hr (1.0 kg/m<sup>2</sup>/hr) relates to drying conditions of the concrete surface (ACI, 1999). The ControlU and Clay3U had an average evaporation rate of 0.43 lb/ft<sup>2</sup>/hr and 0.41 lb/ft<sup>2</sup>/hr over the four hour period, respectively. Therefore, both mixtures at least doubled the evaporation rate given in ACI 305.

Using natural environmental conditions will inherently add variability and limit the time and the location in which plastic shrinkage can be tested. Because of those limitations and to decrease the amount of variables during testing, it is recommended that future plastic shrinkage slabs be evaluated in controlled conditions.

#### 4.3.5 Plastic Shrinkage Cracking Results

As explained in Section 4.3.2 the process of casting slabs that could first produce plastic shrinkage cracks proved difficult. The results below are from four separate slabs, two slabs cast for the ControlU mixture and two slabs cast for the Clay3U mixture. For each mixture, two slabs

were cast in succession from the same batch of concrete. The crack information for each slab is given in Table 4.11.

**Table 4.11 Slab Data**

Mixture		Number of Cracks	Total Crack Length (in)	Avg. Crack Width (in)	Total Crack Area (in <sup>2</sup> )
ControlU	Slab C	7	252.0	0.0413	10.28
	Slab D	10	289.5	0.0351	10.15
Clay3U	Slab E	12	293.0	0.0315	9.11
	Slab F	11	260.0	0.0183	4.77

For the ControlU mixture, the total crack area between the two slabs was similar. Slab C showed less overall crack length than Slab D, but the average crack width was larger. The consistency between the two slabs was the highest in the ControlU mixture compared with all of the previous test slabs. The Clay3U slabs did not show any reduction in crack length when compared to the ControlU slabs, in fact, the Clay3U slabs resulted in slightly more overall crack length. However, the Clay3U slabs differed from the ControlU slabs in regards to crack widths. Clay3U slabs had significantly lower average crack widths than the ControlU slabs. The reduction in crack widths resulted in a lower total crack area. There was a significant difference between the two Clay3U slabs, but both showed a reduction in total crack area when compared to ControlU mixture. Clay3U, like multiple preliminary mixtures, showed a difference in plastic shrinkage between the first and second slabs, both cast from the same batch of concrete. The difference in time between casting the first and second slab (usually around ten minutes) proved in most cases to affect the extent to which the slabs cracked.

## Chapter 5 Conclusions

The research performed for this project was to examine the effects of saturated LWA on shrinkage in both plastic and hardened states in conventional concrete mixtures. The research, and the conclusions herein, is drawn from the research experiences described in the previous chapters.

### 5.1 Phase I- Drying Shrinkage Conclusions

- Replacing a portion of normal weight aggregate with soaked LWA decreased the compressive strength at both early and late ages.
- For the preliminary ASTM C157 results, strain prior to 28 days of age was reduced in the concrete mixtures that contained either shale or clay LWA.
- Casting VWSG in 4x4x10 inch concrete prisms yielded lower strain readings than ASTM C157 results.
- The presence of LWA affected the amount of shrinkage that occurs prior to 24 hours after batching.
- The Clay3 mixture proved to be the most effective in decreasing shrinkage.
- The presence of LWA was not shown to affect the shrinkage of concrete at later ages (following 56 days of age). The difference in strain of the concrete specimens occurred at earlier ages and was maintained, to a degree, throughout the remaining testing period.
- Shale LWA mixtures proved less effective in decreasing concrete strains from the Control than the clay LWA mixtures.

### 5.2 Phase II- Plastic Shrinkage Conclusions

- Developing adequate external restraint is very important when attempting to quantify plastic shrinkage cracks in concrete slabs. The presence of coarse aggregate inhibits the



shrinkage of the slabs, making crack development more difficult to obtain. From our experiences, using steel angle members around the perimeter of the formwork provides sufficient restraint to induce plastic shrinkage cracking in concrete.

- Slump of the concrete mixture is an important factor in plastic shrinkage potential. High slump increases the amount of plastic shrinkage cracks. A low slump will reduce or can even eliminate plastic shrinkage cracks in test slabs. Much effort must be taken to monitor slump when attempting to quantify plastic shrinkage cracks experimentally.
- The 300 lb replacement rate of LWA (1700 lb of total coarse aggregate content including LWA) was not adequately workable for concrete slab applications.
- When comparing the Control and the Clay3U slabs, the total crack lengths were not affected by the use of clay LWA.
- The use of clay LWA reduced the average crack widths, which led to a reduction in total crack area of the test slabs.

### **5.3 Recommendations for Future Research**

- Demolding methods should be investigated in the future to reduce or eliminate the adverse effects that demolding has on the strain results.
- Fine LWA should be examined for its effects on conventional concrete shrinkage.
- For the LWA's used in this project, it is recommended to use the clay LWA instead of the shale LWA.
- For plastic shrinkage analysis, testing should be done under strict, controlled environmental conditions.
- Further testing should be done in testing the effects of internal curing on plastic shrinkage cracking in test slabs.

## References

ACI Committee 305, 1999, "Hot Weather Concreting (ACI 305R-99)," American Concrete Institute, Farmington Hills, Michigan, 1999.

ACI Committee 224, 2001, "Control of Cracking in Concrete Structures (ACI 224R-01)," American Concrete Institute, Farmington Hills, Michigan, 2001.

ACI Committee 213, 2003, "Guide for Structural Lightweight-Aggregate Concrete (ACI 213R-03)," American Concrete Institute, Farmington Hills, Michigan, 2003.

ACI Committee 318, 2008, "Building Code Requirements for Structural Concrete (ACI 318-08) and Commentary," American Concrete Institute, Farmington Hills, Michigan, 2008.

American Concrete Institute, 2010, "ACI Concrete Terminology," Retrieved on June 1, 2012, from American Concrete Institute: <http://www.concrete.org/technical/cct/aci-terminology.aspx>

ASTM Standard C490, 2004, "Standard Practice for Use of Apparatus for the Determination of Length Change of Hardened Cement Paste, Mortar, and Concrete," ASTM International, West Conshohocken, PA, 2004, DOI: 10.1520/C0490-04, [www.astm.org](http://www.astm.org).

ASTM Standard C1579, 2006, "Standard Test Method for Evaluating Plastic Shrinkage Cracking of Restrained Fiber Reinforced Concrete (Using a Steel Form Insert)," ASTM International, West Conshohocken, PA, 2006, DOI: 10.1520/C1579-06, [www.astm.org](http://www.astm.org).

ASTM Standard C157, 2008, "Standard Test Method for Length Change of Hardened Hydraulic-Cement Mortar and Concrete," ASTM International, West Conshohocken, PA, 2008, DOI: 10.1520/C0157\_C0157M-08, [www.astm.org](http://www.astm.org).

ASTM Standard C1698, 2009, "Standard Test Method for Autogenous Strain of Cement Paste and Mortar," ASTM International, West Conshohocken, PA, 2009, DOI: 10.1520/C1698-09, [www.astm.org](http://www.astm.org).

ASTM Standard C511, 2009b, "Standard Specification for Mixing Rooms, Moist Cabinets, Moist Rooms, and Water Storage Tanks Used in the Testing of Hydraulic Cements and Mortars," ASTM International, West Conshohocken, PA, 2009, DOI: 10.1520/C0511, [www.astm.org](http://www.astm.org).

Bentz, D. P. (2002). Influence of Curing Conditions on Water Loss and Hydration in Cement Pastes with and without Fly Ash Substitution. NISTR 6886.

Bentz, D. P., & Weiss, W. J. (2011). Internal Curing: A 2010 State-of-the-Art Review. National Institute of Standards and Technology.

Bentz, D. P., Hansen, K. K., Madsen, H. D., Vallee, F., & Griesel, E. J. (2001). Drying/Hydration in Cement Pastes During Curing. *Materials and Structures*, 557-565.

- Bentz, D. P., Lura, P., & Roberts, J. W. (2005, February). Mixture Proportioning for Internal Curing. *Concrete International* , pp. 35-40.
- Bremner, T. W., & Ries, J. (2009, August). Stephen J. Hayde: Father of the Lightweight Concrete Industry. *Concrete International* , pp. 35-38.
- Byard, B. E. (2011). Early-Age Behavior of Lightweight Aggregate Concrete. Thesis, Auburn University, Auburn.
- Byard, B. E., & Schindler, A. K. (2010). Cracking Tendency of Lightweight Concrete. Auburn: Highway Research Center.
- Espinoza-Hijazin, G., & Lopez, M. (2011, March). Extending Internal Curing to Concrete Mixtures with W/C Higher than 0.42. *Construction and Building Materials* , 25 (3), pp. 1236-1242.
- Floyd, R. (2012). Investigating the Bond of Prestressing Strands in Lightweight Self-Consolidating Concrete. University of Arkansas. Fayetteville: Proquest.
- Hansen, W., & Almudaiheem, J. A. (1987). Ultimate Drying Shrinkage of Concrete-Influence of Major Parameters. *ACI Materials Journal* , 84 (3), 217-223.
- Henkensiefken, R. (2008). Internal Curing in Cementitious Systems Made Using Saturated Lightweight Aggregate. Master's Thesis, Purdue University, Civil Engineering.
- Henkensiefken, R., Bentz, D. P., Nantung, T., & Weiss, J. (2009). Volume Change and Cracking in Internally Cured Mixtures Made with Saturated Lightweight Aggregate Under Sealed and Unsealed Conditions. *Cement and Concrete Composites* (31), 427-437.
- Henkensiefken, R., Briatka, P., Bentz, D. P., Nantung, T., & Weiss, J. (2010, February). Plastic Shrinkage Cracking in Internally Cured Mixtures. *Concrete International* , pp. 49-54.
- Holm, T. A., Bremner, T. W., & Newman, J. B. (1984). Lightweight Aggregate Concrete Subject to Severe Weathering. *Concrete International* , 6 (6), pp. 49-54.
- Holt, E. E. (2001). Early Age Autogenous Shrinkage of Concrete. VTT Publications.
- Jensen, O. M., & Hansen, P. F. (2001). Autogenous Deformation and RH-Change in Perspective. *Cement and Concrete Research* , 31 (12), 1859-1865.
- Kraai, P. P. (1985, September). A Proposed Test to Determine the Cracking Potential Due to Drying Shrinkage of Concrete. *Concrete Construction* , pp. 775-778.
- Lura, P., Mazzota, G. B., Rajabipour, F., & Weiss, J. Evaporation, Settlement, Temperature Evolution, and Development of Plastic Shrinkage Cracks in Mortars with Shrinkage-Reducing Admixtures.

Lura, P., Pease, B., Mazzotta, G. B., Rajabipour, F., & Weiss, J. W. (2007). Influence of Shrinkage-Reducing Admixtures on Development of Plastic Shrinkage Cracking. *ACI Material Journal* , 4 (2), 187-194.

National Cooperative Highway Research Program. (2004). *Synthesis 333: Concrete Bridge Deck Performance*. Washington, D.C.: Transportation Research Board.

Nilson, A. H., Darwin, D., & Dolan, C. W. (2010). *Design of Concrete Structures*. New York: McGraw-Hill.

Pelisser, F., da S. Santos Neto, A. B., La Rovere, H. L., & de Andrade Pinto, R. C. (2010). Effect of the Addition of Synthetic Fibers to Concrete Thin Slabs on Plastic Shrinkage Cracking. *Construction and Building Materials* , 24, 2171-2176.

Qi, C., Weiss, W. J., & Olek, J. (2003). Image Analysis of Plastic Shrinkage Cracking in High Strength Concrete Containing Hybrid Fiber Reinforcement. *International Symposium Dedicated to Surendra Shah*, (pp. 209-218).

Reynolds, D., Browning, J., & Darwin, D. (2009). *Lightweight Aggregates as an Internal Curing Agent for Low-Cracking High-Performance Concrete*. Structural Engineering and Engineering Materials, University of Kansas Center for Research, Inc., Lawrence.

Shaeles, C. A., & Hover, K. C. (1988, November-December). Influence of Mix Proportions and Construction Operations on Plastic Shrinkage Cracking in Thin Slabs. *ACI Materials Journal* , 495-504.

Weber, S., & Reinhardt, H. (1995). A Blend of Aggregates to Support Curing of Concrete. *International Symposium on Structural Lightweight Aggregate Concrete*, (pp. 662-671). Sandefjord.

Weiss, W. J., Bentz, D. P., Schindler, A., & Lura, P. (2012, January). Internal Curing. *Construction Issues* , pp. 10-14.

Weiss, W. J., Yang, W., & Shah, S. P. (1998, July). Shrinkage Cracking of Restrained Concrete Slabs. *Journal of Engineering Mechanics* , 765-774.